

SPECIFICATIONS

WORKSHOP

DPX³ 630 & 1600

MOULDED CASE CIRCUIT BREAKERS

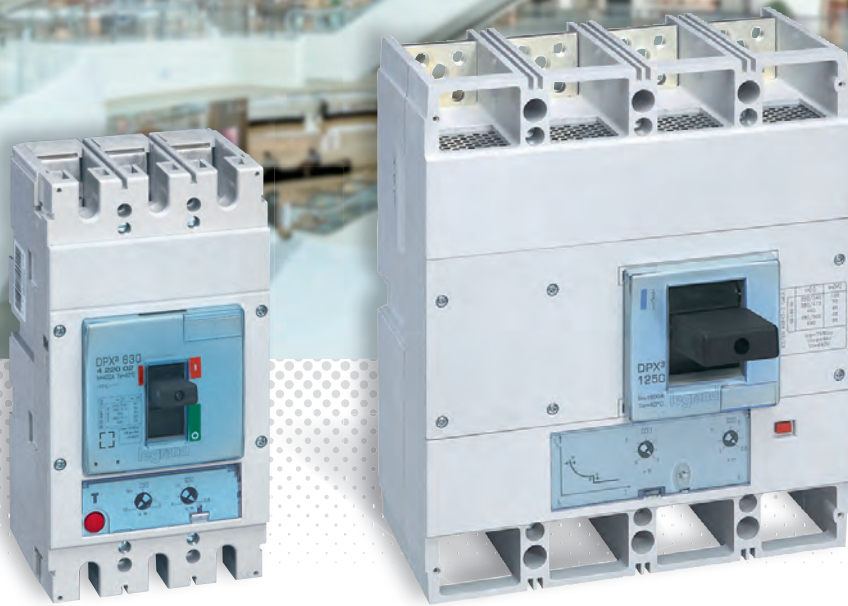

THE GLOBAL SPECIALIST IN ELECTRICAL
AND DIGITAL BUILDING INFRASTRUCTURES

 **legrand**[®]

DPX³ 630 & 1600 RANGE

In addition to reliable and accurate protection, **DPX³ 630 and 1600** circuit breakers provide numerous advantages for your low voltage boards. The wide choice of features and versions covers the needs of all electrical installations, commercial, tertiary and industrial applications. .

The **integrated measurement** allows monitoring of the parameters and consumption of the installation without a device or additional accessory.

The different **selectivity** techniques that can be used to ensure optimal **service continuity**.

The complete range of electric auxiliaries facilitates **operation** and **maintenance**.

Perfect synergy with Legrand XL³ enclosures simplifies the study with XLPRO³ software and the implementation by panel builders.

Many accessories are available and allow you to adapt to all configurations.

Discover in detail the whole range DPX³ 630 and 1600 and all its advantages in this document.

LEGAL INFORMATION

Particular attention must be paid on presentation pictures that do not include personal protective equipment (PPE). PPE are legal and regulatory obligations.

In accordance with its continuous improvement policy, Legrand reserves the right to change the specifications and illustrations without notice. All illustrations, descriptions and technical information included in this document are provided as indications and cannot be held against Legrand.

TABLE OF CONTENTS

DPX³ 630 & 1600 range

Presentation of the offer	2 to 5
DPX ³ 630 – DPX ³ -I 630	6 to 7
DPX ³ 1600 – DPX ³ -I 1600	8 to 11

DPX³ 630

Product description.....	12 to 21
DPX ³ 630 electrical accessories.....	22 to 37
DPX ³ 630 mechanical accessories.....	38 to 51

DPX³ 1600

Product description.....	52 to 57
DPX ³ 1600 electrical accessories.....	58 to 71
DPX ³ 1600 mechanical accessories.....	72 to 85

PCS software

.....	86 to 89
-------	----------

Specific functions

Integrated measurement.....	90 to 93
-----------------------------	----------

Identical accessories

Auxiliary contact Cat.no 4 210 11.....	94
Shunt releases	95
Undervoltage releases	96
Time-lag modules release (800 ms) Cat.no 4 226 23	97
Residual current relay Cat.no 0 260 88	98 to 100

Spare parts

& accessories	102 to 104
---------------------	------------

DPX³ 630 & 1600

RANGE

Presentation of the offer

The strengths of the DPX³ 630 and 1600 circuit breakers are their optimized dimensions, ease of installation, use, accessorizing and reliability.

These circuit breakers are available in thermal magnetic, electronic, electronic with energy unit or magnetic only, with nominal currents from 250 A to 630 A (for DPX³ 630) and from 500 A to 1600 A (for DPX³ 1600). The cutoff powers range from 36 kA to 100 kA for DPX³ 630 and 1600 (70 kA only for a 1600 A intensity).



DPX³ 630-3P



DPX³ 1600-4P

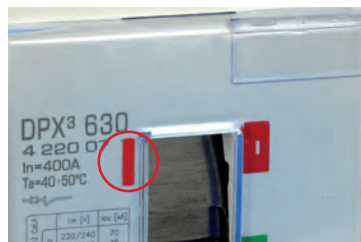
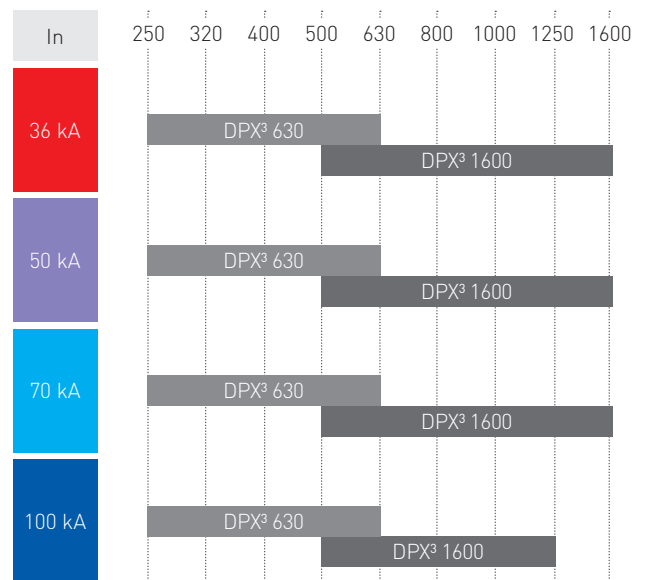

Easy identification of the breaking capacity by colored sticker:



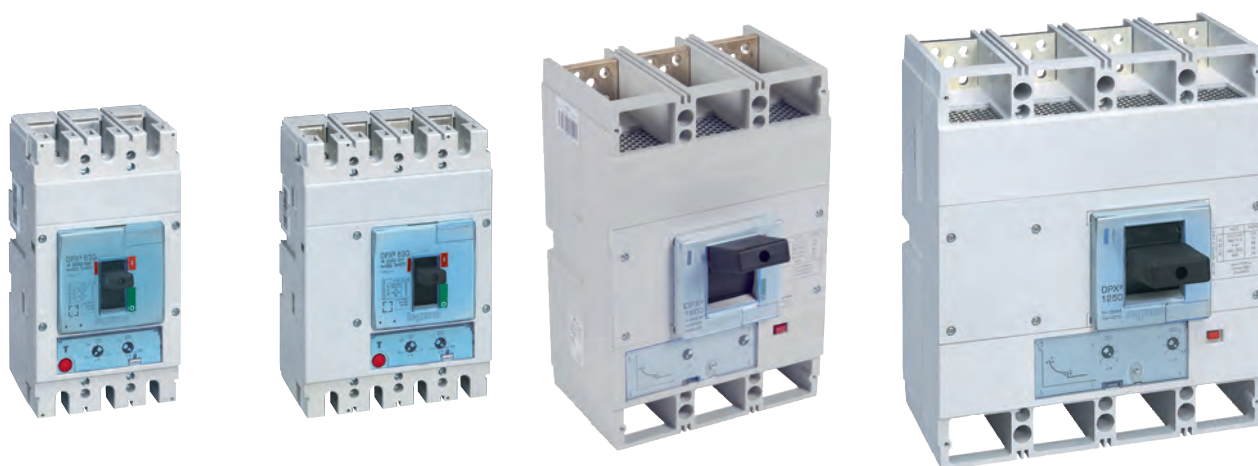

The DPX³ 630 and 1600 range offers a wide choice of versions to meet all requirements:

- Thermal magnetic, electronic, electronic with energy unit depending on the level of protection required.
- Fixed, plug-in or draw-out version depending on the level of maintenance, maintainability and safety required.
- Earth leakage module for DPX³ 630 and residual current relay for DPX³ 1600.

CIRCUIT BREAKERS		DPX ³ 630	DPX ³ 1600
Poles	3 P	•	•
	4 P	•	•
	3P + N/2	• ^[1]	• ^[1]
	3P + N (external neutral)		•
Version	Fixed	•	•
	Plugged-in	•	
	Draw-out	•	•
Tripping	Thermal magnetic	•	•
	Electronic S1	•	•
	Electronic S2	•	•
	ElectronicSg	•	•
	Magnetic only	•	•
Options	Earth leakage protection (integrated)		
	Earth leakage protection (associated)	•	• ^[2]
	Integrated measurement	• ^[3]	• ^[3]

[1] : Thermal magnetic [0 – 50 – 100 % I_n]

[2] : with external residual current relay associated with coils (Shunt Trip) or Undervoltage release (UVR)

[3] : electronic S2, AB and Sg only

DPX³ 630 & 1600 RANGE

	Thermal overload protection		Magnetic short circuit protection			Neutral	Earth fault protection		Measurement
	I _r	t _r	Short delay		Instantaneous	N	I _g	t _g	
			I _{sd}	t _{sd}	I _i				
Thermal magnetic	0.8 – 1 x I _n	-	5-10 x I _n	-	-	100% except for 3P+N/2	-	-	-
Electronic S1	0.4 – 1 x I _n	5s (permanent)	1.5 – 10 x I _r ^{(A) (B)}	100 ms (permanent)	^{(A) (B)} F ⁽¹⁾	OFF-50%-100%	-	-	-
Electronic S2	0.4 – 1 x I _n	3 – 30s	1.5 – 10 x I _r ^{(A) (B)}	0 – 500ms	^(A) F ⁽¹⁾ F ⁽²⁾	(OFF-0.5-1-1.5-2)xI _r	-	-	YES
Electronic Sg	0.4 – 1 x I _n	3 – 30s	1.5 – 10 x I _r ^{(A) (B)}	0 – 500ms	^(A) F ⁽¹⁾ F ⁽²⁾	(OFF-0.5-1-1.5-2)xI _r	R	R	YES
Magnetic	-	-	E : 1.5 - 10 x I _r ^(B)	E : 0 - 500 ms	^{(A) (B)} F ⁽¹⁾ F ⁽²⁾	E : (0 - 0.5 - 1) x I _n	-	-	-
	-	-	MT : 5 - 10 x I _n	MT : -	^(A) F ⁽¹⁾ F ⁽²⁾	MT : 100%	-	-	-
AB	Preset	3- 30s	1.5- 10 x I _r ^(B)	0 -500ms	I _{sd} F ⁽¹⁾ F ⁽²⁾	(0-0.5- 1) xI _r	-	-	YES

[A] : 630 A I_{sd} ≤ I_i, only for DPX³ 630 - I_n 630 A - I_f < I_{sd} max

[B] : Except DPX³ 630 - 630 A : I_{sd} maxi. = 5000 A

R : Adjustable (see catalogue pages for adjustment ranges)

F(1) : DPX³ 1600 - I_{cw} = 15000 A (1250 A) or 20000 (1600 A)

F(2) : SEL : H/L



An Sg trigger type circuit breaker behaves as a S2 if the IG = OFF setting.

Electronic trigger curve allure

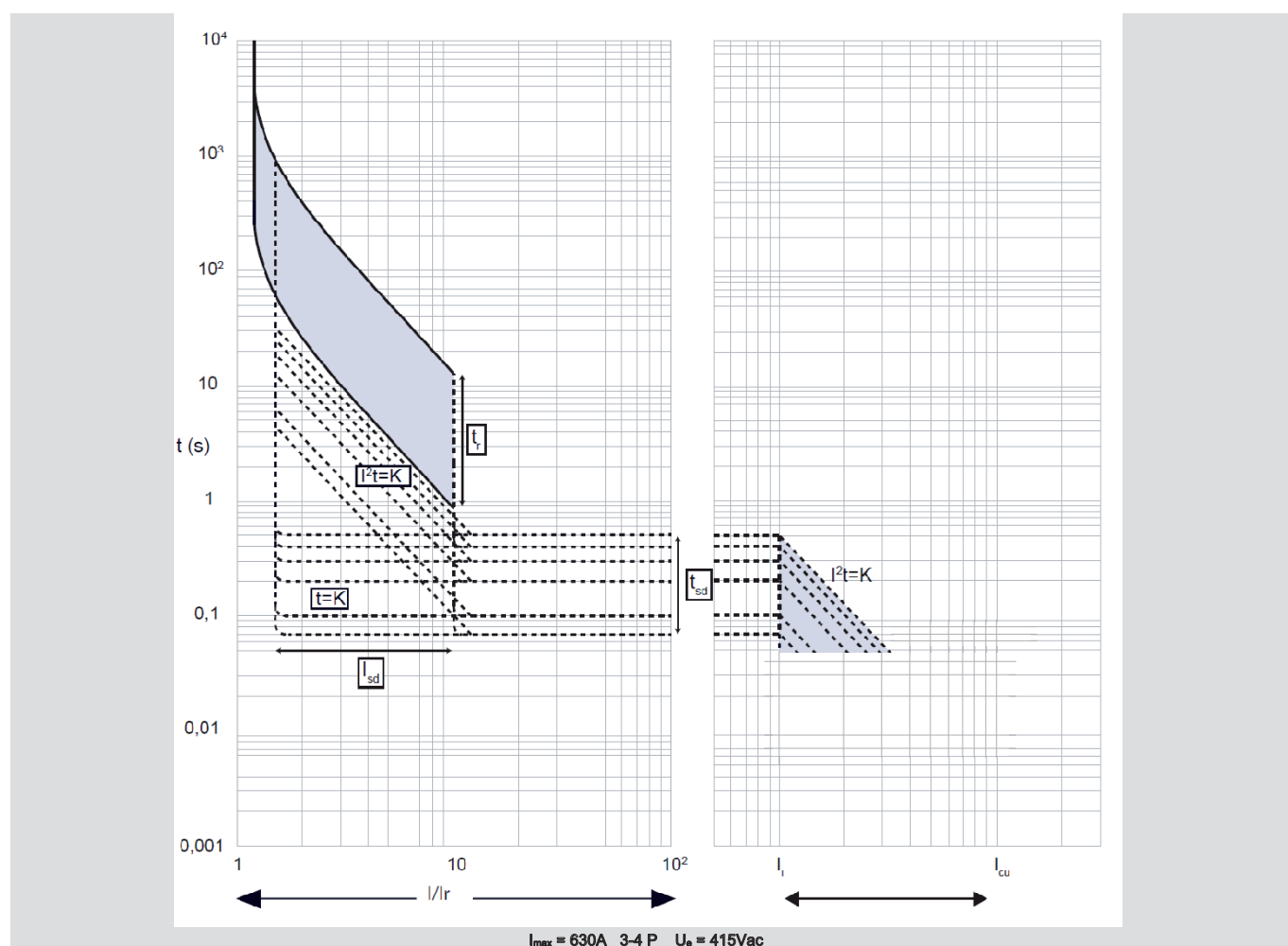

Valeur	Description
t	time
I	current
I _n	rated current
I _r	current setting for long delay
t _r	short delay tripping time
I _{sd}	current setting for short delay
t _{sd}	short delay tripping time
I ² t = K	energy
I = K	constant time of triggering

DPX³ 630 - DPX³-I 630

PRESENTATION

DPX³ 630 MCCBs are integrated in XL³ enclosures on plate only.

The DPX³ 630 thermal magnetic circuit breakers ensure the disconnection, control, breaking and protection of power lines, they are available with:

- 4 breaking capacities : 36 kA, 50 kA, 70 kA, 100 kA
- 5 sizes : 250 A, 320 A, 400 A, 500 A, 630 A
- Versions in 3P, 3P+N et 4P
- A downstream earth leakage module
- Conforming to IEC 60947-2 standard



SIZE	DPX ³ 630 THERMAL MAGNETIC											
	36 kA			50 kA			70 kA			100 kA		
	3P	4P	3P+N/2	3P	4P	3P+N/2	3P	4P	3P+N/2	3P	4P	3P+N/2
250 A	4 220 00	4 220 05	-	4 220 14	4 220 19	-	4 220 28	4 220 33	-	4 220 42	4 220 47	-
320 A	4 220 01	4 220 06	4 220 10	4 220 15	4 220 20	4 220 24	4 220 29	4 220 34	4 220 38	4 220 43	4 220 48	4 220 52
400 A	4 220 02	4 220 07	4 220 11	4 220 16	4 220 21	4 220 25	4 220 30	4 220 35	4 220 39	4 220 44	4 220 49	4 220 53
500 A	4 220 03	4 220 08	4 220 12	4 220 17	4 220 22	4 220 26	4 220 31	4 220 36	4 220 40	4 220 45	4 220 50	4 220 54
630 A	4 220 04	4 220 09	4 220 13	4 220 18	4 220 23	4 220 27	4 220 32	4 220 37	4 220 41	4 220 46	4 220 51	4 220 55

DPX³ 630 electronic circuit breakers (with and without measurement/Earth protection) ensure the disconnection, control, breaking and protection of power lines. They are available with:

- 4 breaking capacities: 36 kA, 50 kA, 70 kA, 100 kA
- 5 sizes : 250 A, 320 A, 400 A, 500 A, 630 A
- Versions in 3P, 4P with neutral setting
- A downstream earth leakage module
- Conforming to IEC 60947-2

SIZE	DPX ³ 630 ELEC S1							
	36 kA		50 kA		70 kA		100 kA	
	3P	4P	3P	4P	3P	4P	3P	4P
250 A	4 22498	4 225 03	4 225 08	4 225 13	4 22518	4 225 23	4 22528	4 225 33
320A	4 224 99	4 225 04	4 225 09	4 225 14	4 225 19	4 225 24	4 225 29	4 225 34
400 A	4 225 00	4 225 05	4 225 10	4 225 15	4 225 20	4 225 25	4 225 30	4 225 35
500 A	4 225 01	4 225 06	4 225 11	4 225 16	4 225 21	4 225 26	4 225 31	4 225 36
630 A	4 225 02	4 225 07	4 225 12	4 225 17	4 225 22	4 225 27	4 225 32	4 225 37

Size	DPX ³ 630 ELEC S2								DPX ³ 630 ELEC S2 + measurement							
	36 kA		50 kA		70 kA		100 kA		36 kA		50 kA		70 kA		100 kA	
	3P	4P	3P	4P	3P	4P	3P	4P	3P	4P	3P	4P	3P	4P	3P	4P
250 A	4 220 56	4 220 61	4 220 66	4 220 71	4 220 76	4 220 81	4 220 86	4 220 91	4 220 96	4 221 01	4 221 06	4 221 11	4 221 16	4 221 21	4 221 26	4 221 31
320 A	4 220 57	4 220 62	4 220 67	4 220 72	4 220 77	4 220 82	4 220 87	4 220 92	4 220 97	4 221 02	4 221 07	4 221 12	4 221 17	4 221 22	4 221 27	4 221 32
400 A	4 220 58	4 220 63	4 220 68	4 220 73	4 220 78	4 220 83	4 220 88	4 220 93	4 220 98	4 221 03	4 221 08	4 221 13	4 221 18	4 221 23	4 221 28	4 221 33
500 A	4 220 59	4 220 64	4 220 69	4 220 74	4 220 79	4 220 84	4 220 89	4 220 94	4 220 99	4 221 04	4 221 09	4 221 14	4 221 19	4 221 24	4 221 29	4 221 34
630 A	4 220 60	4 220 65	4 220 70	4 220 75	4 220 80	4 220 85	4 220 90	4 220 95	4 221 00	4 221 05	4 221 10	4 221 15	4 221 20	4 221 25	4 221 30	4 221 35

Size	DPX ³ 630 ELEC Sg							
	36 kA		50 kA		70 kA		100 kA	
	3P	4P	3P	4P	3P	4P	3P	4P
250 A	4 221 36	4 221 41	4 221 46	4 221 51	4 221 56	4 221 61	4 221 66	4 221 71
320 A	4 221 37	4 221 42	4 221 47	4 221 52	4 221 57	4 221 62	4 221 67	4 221 72
400 A	4 221 38	4 221 43	4 221 48	4 221 53	4 221 58	4 221 63	4 221 68	4 221 73
500 A	4 221 39	4 221 44	4 221 49	4 221 54	4 221 59	4 221 64	4 221 69	4 221 74
630 A	4 221 40	4 221 45	4 221 50	4 221 55	4 221 60	4 221 65	4 221 70	4 221 75

Size	DPX ³ 630 ELEC Sg + measurement							
	36 kA		50 kA		70 kA		100 kA	
	3P	4P	3P	4P	3P	4P	3P	4P
250 A	4 221 76	4 221 81	4 221 86	4 221 91	4 221 96	4 222 01	4 222 06	4 222 11
320 A	4 221 77	4 221 82	4 221 87	4 221 92	4 221 97	4 222 02	4 222 07	4 222 12
400 A	4 221 78	4 221 83	4 221 88	4 221 93	4 221 98	4 222 03	4 222 08	4 222 13
500 A	4 221 79	4 221 84	4 221 89	4 221 94	4 221 99	4 222 04	4 222 09	4 222 14
630 A	4 221 80	4 221 85	4 221 90	4 221 95	4 222 00	4 222 05	4 222 10	4 222 15

The DPX³-I 630 switches ensure the on-load circuit breaking and electrical circuit isolation. They are available with:

- 2 sizes : 400 A, 630 A
- 3P and 4P versions
- A downstream earth leakage module
- Conforming to IEC 60947-3

Size	DPX ³ - I	
	3P	4P
400 A	4 222 16	4 222 18
630 A	4 222 17	4 222 19

DPX³ 1600 - DPX³-I 1600

PRESENTATION

DPX³ 1600 MCCBs are integrated in XL³ on plate only. The DPX³ 1600 thermal magnetic circuit breakers ensure the disconnection, control, breaking and protection of power lines, they are available with:

- 4 breaking capacities : 36 kA, 50 kA, 70 kA, 100 kA
- 5 sizes : 500 A, 630 A, 800 A, 1000 A, 1250 A
- 3P or 3P + N (external neutral) or 4P versions
- Conforming to IEC 60947-2



Size	DPX ³ 1600 MT											
	36 kA			50 kA			70 kA			100 kA		
	3P	4P	3P+N/2	3P	4P	3P+N/2	3P	4P	3P+N/2	3P	4P	3P+N/2
500 A	4 222 50	4 222 55	-	4 222 62	4 222 67	-	4 222 74	4 222 79	-	4 222 86	4 222 91	-
630 A	4 222 51	4 222 56	-	4 222 63	4 222 68	-	4 222 75	4 222 80	-	4 222 87	4 222 92	-
800 A	4 222 52	4 222 57	-	4 222 64	4 222 69	-	4 222 76	4 222 81	-	4 222 88	4 222 93	-
1000 A	4 222 53	4 222 58	4 222 60	4 222 65	4 222 70	4 222 72	4 222 77	4 222 82	4 222 84	4 222 89	4 222 94	4 222 96
1250 A	4 222 54	4 222 59	4 222 61	4 222 66	4 222 71	4 222 73	4 222 78	4 222 83	4 222 85	4 222 90	4 222 95	4 222 97

DPX³ 1600 electronic circuit breakers (with and without measurement/Earth protection) ensure the disconnection, control, breaking and protection of power lines. They are available with:

- 4 breaking capacities : 36 kA, 50 kA, 70 kA, 100 kA
- 6 sizes : 500 A, 630 A, 800 A, 1000 A, 1250 A, 1600 A
- 3P, 4P or 3P + N (external neutral) versions
- Tripping type : S1 – S2 – Sg
- Conforming to IEC 60947-2

Size	DPX ³ 1600 ELEC S1							
	36 kA		50 kA		70 kA		100 kA	
	3P	4P	3P	4P	3P	4P	3P	4P
500 A	4 225 38	4 225 44	4 225 50	4 225 56	4 225 62	4 225 68	4 225 74	4 225 80
630 A	4 225 39	4 225 45	4 225 51	4 225 57	4 225 63	4 225 69	4 225 75	4 225 81
800 A	4 225 40	4 225 46	4 225 52	4 225 58	4 225 64	4 225 70	4 225 76	4 225 82
1000 A	4 225 41	4 225 47	4 225 53	4 225 59	4 225 65	4 225 71	4 225 77	4 225 83
1250 A	4 225 42	4 225 48	4 225 54	4 225 60	4 225 66	4 225 72	4 225 78	4 225 84
1600 A	4 225 43	4 225 49	4 225 55	4 225 61	4 225 67	4 225 73	-	-

Size	DPX ³ 1600 ELEC S2								DPX ³ 1600 ELEC S2 + measurement							
	36 kA		50 kA		70 kA		100 kA		36 kA		50 kA		70 kA		100 kA	
	3P	4P	3P	4P	3P	4P	3P	4P	3P	4P	3P	4P	3P	4P	3P	4P
500 A	4 222 98	4 223 04	4 223 10	4 223 16	4 223 22	4 223 28	4 223 34	4 223 40	4 223 46	4 223 52	4 223 58	4 223 64	4 223 70	4 223 76	4 223 82	4 223 88
630 A	4 222 99	4 223 05	4 223 11	4 223 17	4 223 23	4 223 29	4 223 35	4 223 41	4 223 47	4 223 53	4 223 59	4 223 65	4 223 71	4 223 77	4 223 83	4 223 89
800 A	4 223 00	4 223 06	4 223 12	4 223 18	4 223 24	4 223 30	4 223 36	4 223 42	4 223 48	4 223 54	4 223 60	4 223 66	4 223 72	4 223 78	4 223 84	4 223 90
1000 A	4 223 01	4 223 07	4 223 13	4 223 19	4 223 25	4 223 31	4 223 37	4 223 43	4 223 49	4 223 55	4 223 61	4 223 67	4 223 73	4 223 79	4 223 85	4 223 91
1250 A	4 223 02	4 223 08	4 223 14	4 223 20	4 223 26	4 223 32	4 223 38	4 223 44	4 223 50	4 223 56	4 223 62	4 223 68	4 223 74	4 223 80	4 223 86	4 223 92
1600 A	4 223 03	4 223 09	4 223 15	4 223 21	4 223 27	4 223 33	-	-	4 223 51	4 223 57	4 223 63	4 223 69	4 223 75	4 223 81	-	-

Size	DPX ³ 1600 ELEC Sg								DPX ³ 1600 ELEC Sg + measurement							
	36 kA		50 kA		70 kA		100 kA		36 kA		50 kA		70 kA		100 kA	
	3P	4P	3P	4P	3P	4P	3P	4P	3P	4P	3P	4P	3P	4P	3P	4P
500 A	4 223 94	4 224 00	4 224 06	4 224 12	4 224 18	4 224 24	4 224 30	4 224 36	4 224 42	4 224 48	4 224 54	4 224 60	4 224 66	4 224 72	4 224 78	4 224 84
630 A	4 223 95	4 224 01	4 224 07	4 224 13	4 224 19	4 224 25	4 224 31	4 224 37	4 224 43	4 224 49	4 224 55	4 224 61	4 224 67	4 224 73	4 224 79	4 224 85
800 A	4 223 96	4 224 02	4 224 08	4 224 14	4 224 20	4 224 26	4 224 32	4 224 38	4 224 44	4 224 50	4 224 56	4 224 62	4 224 68	4 224 74	4 224 80	4 224 86
1000 A	4 223 97	4 224 03	4 224 09	4 224 15	4 224 21	4 224 27	4 224 33	4 224 39	4 224 45	4 224 51	4 224 57	4 224 63	4 224 69	4 224 75	4 224 81	4 224 87
1250 A	4 223 98	4 224 04	4 224 10	4 224 16	4 224 22	4 224 28	4 224 34	4 224 40	4 224 46	4 224 52	4 224 58	4 224 64	4 224 70	4 224 76	4 224 82	4 224 88
1600 A	4 223 99	4 224 05	4 224 11	4 224 17	4 224 23	4 224 29	-	-	4 224 47	4 224 53	4 224 59	4 224 65	4 224 71	4 224 77	-	-

DPX³ 630 & 1600 RANGE

The DPX³-I 1600 switches provide on-load circuit breaking and disconnection of electrical circuits. They are available with:

- 4 sizes : 630 A, 800 A, 1250 A, 1600 A
- 3P or 4P versions
- Conforming to IEC 60947-3

	DPX ³ - I 1600	
Size	3P	4P
630 A	4 224 90	4 224 94
800 A	4 224 91	4 224 95
1250 A	4 224 92	4 224 96
1600 A	4 224 93	4 224 97



IMPLEMENTATION

■ Minimum installation distance

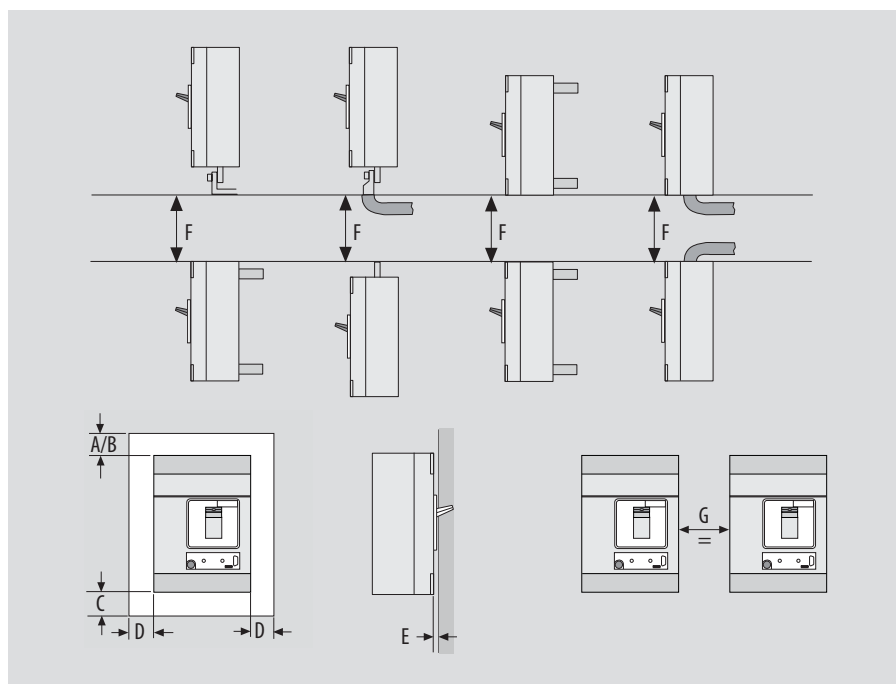

	Electrical bonded wall	Insulated wall	Electrical bonded wall	Metal wall	Faceplate	Distance between 2 circuit breakers	
	A (mm)	B (mm)	C (mm)	D (mm)	E (mm)	F (mm)	G (mm)
DPX ³ 630	70	25	25	25	0	160	0
DPX ³ 1600	90	40	40	40	0	160	0

DPX³ 630

Product description

1 FRONT FACE OF THE CIRCUIT BREAKER



Example of settings (thermal magnetic circuit breaker) :

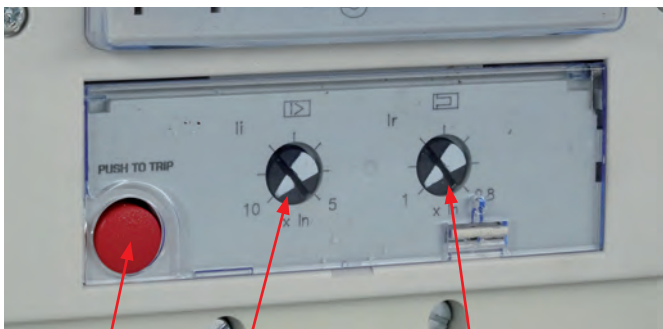

Mechanical
test button

Magnetic
protection setting

Thermal
protection setting



Settings are sealable.

2 FRONT FACE OF THE SWITCH

The DPX³-I 630 switches provide on-load circuit breaking and disconnection of electrical circuits.



The DPX³-I switches are easily identifiable with the gray handle.

3 HANDLE POSITION (ON - TRIPPED - OFF)



Closed (ON).



Tripped.



Open (OFF).

4 DPX³ 630 SETTINGS

	Thermal overload protection		Magnetic short circuit protection		Earth faults protection		Neutral setting	Associated earth leakage module	
								I Δ n	Δ t
Thermal magnetic	Ir adjustable 0.8-1 x I _n	-	Ii adjustable 5-10 x I _n	-	-	-	-	Adjustable 0.03 - 0.3 - 1 - 3 A	Adjustable 0 - 0.3 - 1 - 3 s ⁽¹⁾
Electronic S1	Ir adjustable 0.4 to 1 I _n	Permanent = 5s (MEM ON)	I _{sd} adjustable 1.5 - 2 - 2.5 - 3 - 4 - 5 - 6 - 7 - 8 - 10 x I _r	Permanent = 100ms	-	-	OFF - 0.5 - 1 x I _n	Adjustable 0.03 - 0.3 - 1 - 3 A	Adjustable 0 - 0.3 - 1 - 3 s ⁽¹⁾
Electronic S2	Ir adjustable (1A by 1A) 0.4 to 1 x I _n	tr adjustable (memory ON or memory OFF) 3 - 5 - 10 - 15 - 20 - 25 - 30 s	I _{sd} adjustable 1.5 - 2 - 2.5 - 3 - 4 - 5 - 6 - 7 - 8 - 9 - 10 x I _r	tsd adjustable (I ² t=k or t = k) 0 - 0.1 - 0.2 - 0.3 - 0.4 - 0.5 s	-	-	OFF - 0.5 - 1 - 1.5 - 2 x I _r	Adjustable 0.03 - 0.3 - 1 - 3 A	Adjustable 0 - 0.3 - 1 - 3 s ⁽¹⁾
Electronic Sg	Ir adjustable (1A by 1A) 0.4 to 1 x I _n	tr adjustable (memory ON or memory OFF) 3 - 5 - 10 - 15 - 20 - 25 - 30 s	I _{sd} adjustable 1.5 - 2 - 2.5 - 3 - 4 - 5 - 6 - 7 - 8 - 9 - 10 x I _r	tsd adjustable (I ² t=k or t = k) 0 - 0.1 - 0.2 - 0.3 - 0.4 - 0.5 s	I _g adjustable 0.2 - 0.3 - 0.4 - 0.5 - 0.6 - 0.7 - 0.8 - 0.9 - 1 x I _n	t _g adjustable 0 - 0.1 - 0.2 - 0.5 - 1 s (t=k)	OFF - 0.5 - 1 - 1.5 - 2 x I _r	-	-
Magnetic	-	-	Ii adjustable 5 - 10 x I _n	-	-	-	-	Adjustable 0.03 - 0.3 - 1 - 3 A	Adjustable 0 - 0.3 - 1 - 3 s ⁽¹⁾
Magnetic electronic	-	-	I _{sd} adjustable 1.5 - 2 - 2.5 - 3 - 4 - 5 - 6 - 7 - 8 - 9 - 10 x I _n	-	-	-	-	Adjustable 0.03 - 0.3 - 1 - 3 A	Adjustable 0 - 0.3 - 1 - 3 s ⁽¹⁾
AB	Ir adjustable 260 or 280 or 300 or 320 or 340 or 360 or 380 or 400A	tr adjustable (memory ON or memory OFF) 3 - 5 - 10 - 15 - 20 - 25 - 30 s	I _{sd} adjustable 1.5 - 2 - 2.5 - 3 - 4 - 5 - 6 - 7 - 8 - 9 - 10 I _r	tsd adjustable (I ² t=k or I = k) 0 - 0.1 - 0.2 - 0.3 - 0.4 - 0.5 s	-	-	OFF-50%- 100%''	Adjustable 0.03 - 0.3 - 1 - 3 A	Adjustable 0 - 0.3 - 1 - 3 s ⁽¹⁾

(1) : The setting at 0.03 a must have a time-lag of 0 seconds.

For thermal magnetic circuit breakers, only the settings corresponding to the marking positions have been tested. The other setting values are given as an indication.

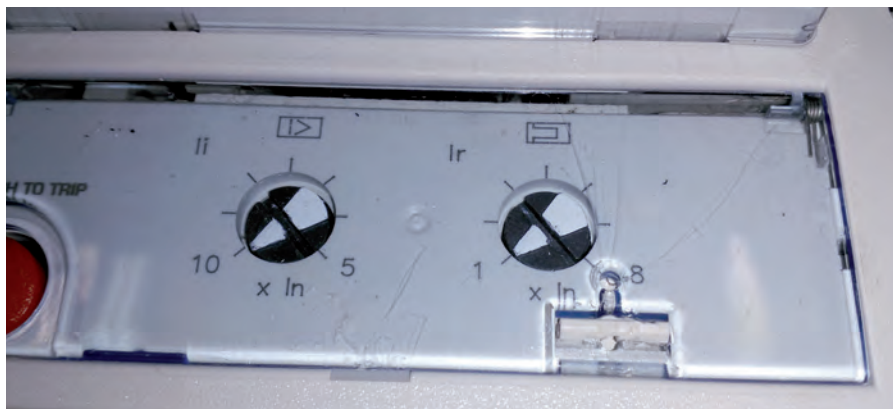

Electronic card consumptions :

- Electronic DPX³: 50 mA
- Electronic DPX³ with measurement: 62.5 mA
- DPX³ electronic earth leakage: 50 mA
- DPX³ electronic earth leakage with measurement: 62.5 mA

DPX³ 630 MT

Thermal : Ir			Current (A)				
Catch	Multiplying factor of Ir	Mark	250	320	400	500	630
1	0.80	0.8	200	256	320	400	504
2	0.83		208	266	332	415	523
3	0.86		215	275	344	430	542
4	0.90		225	288	360	450	567
5	0.93		233	298	372	465	586
6	0.96		240	307	384	480	605
7	1.00	1	250	320	400	500	630

Magnetic : Ii			Current (A)				
Catch	Multiplying factor of Ir	Mark	250	320	400	500	630
1	5.0	5	1250	1600	2000	2500	3150
2	5.8		1450	1856	2320	2900	3654
3	6.7		1675	2144	2680	3350	4221
4	7.5		1875	2400	3000	3750	4725
5	8.3		2075	2656	3320	4150	5229
6	9.2		2300	2944	3680	4600	5796
7	10.0	10	2500	3200	4000	5000	6300

i The normative tolerances of the Ir and Ii values are at +/-20% at 40-50 °

DPX³ 630 Electronic S1

Thermal : Ir			Current (A)				
Catch	Multiplying factor of Ir	Mark	250	320	400	500	630
1	0.40	0.40*	100*	128*	160*	200*	252*
2	0.45	0.45*	113*	144*	180*	225*	284*
3	0.50	0.50*	125*	160*	200*	250*	315*
4	0.55	0.55*	138*	176*	220*	275*	347*
5	0.60	0.60*	150*	192*	240*	300*	378*
6	0.65	0.65*	163*	208*	260*	325*	410*
7	0.70	0.70*	175*	224*	280*	350*	441*
8	0.75	0.75*	188*	240*	300*	375*	473*
9	0.85	0.85*	213*	272*	340*	425*	536*
10	0.95	0.95*	238*	304	380*	475*	599*
	1.00		250	320	400	500	630

* adjustable settings at 0 - 0.005 - 0.01 - 0.015 - 0.02 - 0.025 - 0.03 - 0.035 - 0.04 - 0.05

Magnetic : Isd			Current (A)				
Catch	Multiplying factor of Ir	Mark	250	320	400	500	630
1	1.5	1.5	150 to 375	192 to 480	240 to 600	300 to 750	378 to 945
2	2.0	2.0	200 to 500	256 to 640	320 to 800	400 to 1000	504 to 1260
3	2.5	2.5	250 to 625	320 to 800	400 to 1000	500 to 1250	630 to 1575
4	3.0	3.0	300 to 750	384 to 960	480 to 1200	600 to 1500	756 to 1890
5	4.0	4.0	400 to 1000	512 to 1280	640 to 1600	800 to 2000	1008 to 2520
6	5.0	5.0	500 to 1250	640 to 1600	800 to 2000	1000 to 2500	1260 to 3150
7	6.0	6.0	600 to 1500	768 to 1920	960 to 2400	1200 to 3000	1512 to 3780
8	7.0	7.0	700 to 1750	896 to 2240	1120 to 2800	1400 to 4500	1764 to 4410
9	8.0	8.0	800 to 2000	1024 to 2560	1280 to 3200	1600 to 4000	2016 to 5000
10	10.0	10.0	1000 to 2500	1280 to 3200	2600 to 4000	2000 to 5000	2520 to 5000

Isd values at +/- 10% in amps.



For S1, tr is permanent at 5 sec.
tsd=100ms permanent

DPX³ 630 Electronic S2

Thermal : Ir			Current (A)				
LCD	Adjustments	Adjustment range	250	320	400	500	630
	0.4 to 1	1A by 1A	100 to 250	128 to 320	160 to 400	200 to 500	252 to 630

* adjustable settings to 0 - 0.005 - 0.01 - 0.015 - 0.02 - 0.025 - 0.03 - 0.035 - 0.04 - 0.05

Magnetic : Isd			Current (A)				
LCD	Multiplying factor of Ir	Adjustment range	250	320	400	500	630
	1.5	1.5	150 to 375	192 to 480	240 to 600	300 to 750	378 to 945
	2.0	2.0	200 to 500	256 to 640	320 to 800	400 to 1000	504 to 1260
	2.5	2.5	250 to 625	320 to 800	400 to 1000	500 to 1250	630 to 1575
	3.0	3.0	300 to 750	384 to 960	480 to 1200	600 to 1500	756 to 1890
	4.0	4.0	400 to 1000	512 to 1280	640 to 1600	800 to 2000	1008 to 2520
	5.0	5.0	500 to 1250	640 to 1600	800 to 2000	1000 to 2500	1260 to 3150
	6.0	6.0	600 to 1500	768 to 1920	960 to 2400	1200 to 3000	1512 to 3780
	7.0	7.0	700 to 1750	896 to 2240	1120 to 2800	1400 to 3500	1764 to 4410
	8.0	8.0	800 to 2000	1024 to 2560	1280 to 3200	1600 to 4000	2016 to 5000
	9.0	9.0	900 to 2250	1152 to 2880	1440 to 3600	1800 to 4500	2268 to 5000
	10.0	10.0	1000 to 2500	1280 to 3200	1600 to 4000	2000 to 5000	2520 to 5000

tsd = 0 - 100 - 200 - 300 - 400 - 500 ms (t = K)

tsd = 0 - 100 - 200 - 300 - 400 - 500 ms (I²t = K) (**)

(**) @ 12 Ir

Isd values at +/-10% in amps.

DPX³ 630 Electronic Sg

Thermal : I _r			Current (A)				
LCD	Adjustments	Adjustment range	250	320	400	500	630
	0.4 to 1	1A by 1A	100 to 250	128 to 320	160 to 400	200 to 500	252 to 630

Magnetic : I _{sd}			Current (A)				
LCD	Multiplying factor of I _r	Adjustment range	250	320	400	500	630
	1.5	1.5	150 to 375	192 to 480	240 to 600	300 to 750	378 to 945
	2.0	2.0	200 to 500	256 to 640	320 to 800	400 to 1000	504 to 1260
	2.5	2.5	250 to 625	320 to 800	400 to 1000	500 to 1250	630 to 1575
	3.0	3.0	300 to 750	384 to 960	480 to 1200	600 to 1500	756 to 1890
	4.0	4.0	400 to 1000	512 to 1280	640 to 1600	800 to 2000	1008 to 2520
	5.0	5.0	500 to 1250	640 to 1600	800 to 2000	1000 to 2500	1260 to 3150
	6.0	6.0	600 to 1500	768 to 1920	960 to 2400	1200 to 3000	1512 to 3780
	7.0	7.0	700 to 1750	896 to 2240	1120 to 2800	1400 to 3500	1764 to 4410
	8.0	8.0	800 to 2000	1024 to 2560	1280 to 3200	1600 to 4000	2016 to 5000
	9.0	9.0	900 to 2250	1152 to 2880	1440 to 3600	1800 to 4500	2268 to 5000
	10.0	10.0	1000 to 2500	1280 to 3200	1600 to 4000	2000 to 5000	2520 to 5000

Earth fault protection I _g			Current (A)				
LCD	Multiplying factor of I _r	Adjustment range	250	320	400	500	630
	0.2	0.2	50	64	80	100	126
	0.3	0.3	75	96	120	150	189
	0.4	0.4	100	128	160	200	252
	0.5	0.5	125	160	200	250	315
	0.6	0.6	150	192	240	300	378
	0.7	0.7	175	224	280	350	441
	0.8	0.8	200	256	320	400	504
	0.9	0.9	225	288	360	450	567
	1.0	1.0	250	320	400	500	630
	OFF	OFF	S2	S2	S2	S2	S2

tsd = 0 – 100 – 200 – 300 – 400 – 500 ms (t = K)
 tsd = 0 – 100 – 200 – 300 – 400 – 500 ms (I²t = k) (**)
 (**) @ 12 I_r
 tg : 0.1 – 0.2 – 0.3 – 0.4 – 0.5 – 1 s (t=k)
 ISD values at +/-10% in amps.

5 TRANSFER SWITCHES

The transfer switches plates are supplied with mechanical interlock and accessories.

-Catalogue numbers of the fixing devices + plates + faceplate depending on the mounting:

Version	Position	Configuration	Accessory	XL ³		
				Fixing device	Plate	Faceplate
Fixed	vertical	transfer switch	-	0 210 66	-	0 21067
Plugged-in	vertical	single	Nothing	0 210 60	0 210 62	0 210 64
			Earth leakage	0 210 61	0 210 63	0 210 65
		transfer	Nothing	0 210 66	-	0 210 67
	Motor		0 210 66	-	0 210 67	
	horizontal	transfer switch	Nothing	0 210 73	-	0 210 76
Draw-out	vertical	single	Nothing	0 210 60	0 210 62	0 210 70
			Earth leakage	0 210 61	0 210 63	0 210 71
			Motor	0 210 60	0 210 62	0 210 72
		transfer switch	Nothing	0 210 66	-	0 210 68
			Motor	0 210 66	-	0 210 69
			Nothing	0 210 73	-	0 210 74
	horizontal	transfer switch	Nothing	0 210 73	-	0 210 74
			Motor	0 210 73	-	0 210 75

New catalogue number	Previous catalogue number	
0 210 60	0 207 21	Fixing device for 1-2 DPX ³ 630 plug-in/draw-out
0 210 61	0 207 23	Fixing device for 1-2 DPX ³ 630 plug-in/draw-out+ e.l.c.bs
0 210 62	0 207 87	Mounting plate for device only in vertical position
0 210 63	0 207 88	Mounting plate for device with e.l.c.bs in vertical position
0 210 64	0 212 20	Metal faceplate for 1-2 DPX ³ 630 plug-in
0 210 65	0 212 22	Metal faceplate for 1-2 DPX ³ 630 plug-in+ e.l.c.bs
0 210 66	0 206 76	Fixing automatic transfer switches DPX ³ 630 devices in vertical position (fixed/draw-out versions)
0 210 67	0 209 76	Metal faceplates for automatic transfer switches for fixed version DPX ³ 630 (vertical)
0 210 68	0 212 94	Metal faceplates for automatic transfer switches for draw-out DPX ³ 630 in vertical position
0 210 69	0 212 95	DPX ³ 630 faceplate + motor driven handle + transfer switches for draw-out DPX ³ 630 in vertical position
0 210 70	0 212 21	Metal faceplates for draw-out devices
0 210 71	0 212 23	Metal faceplate for 1 DPX ³ 630 draw-out with e.l.c.bs in vertical position
0 210 72	0 212 04	Metal faceplate 1 draw-out device without e.l.c.bs in vertical position with motor-driven handle
0 210 73	0 206 77	Fixing automatic transfer switch for 2 DPX ³ 630 in horizontal position
0 210 74	0 212 93	Metal faceplate for automatic transfer switch for 2 draw-out DPX ³ 630 in horizontal position
0 210 75	0 212 97	Metal faceplate for automatic transfer switch for 2 draw-out DPX ³ 630 with handle in horizontal position
0 210 76	0 212 98	Metal faceplate for automatic transfer switch for 2 fixed DPX ³ 630 in horizontal position

■ Principle

The aim is to combine 2 devices motorized or not and to prevent the possibility of closing the 2 at the same time using the mechanical interlock.

■ Product preparation

Prepare your devices according to the installation leaflet supplied instructions specified in the package according to the configuration.

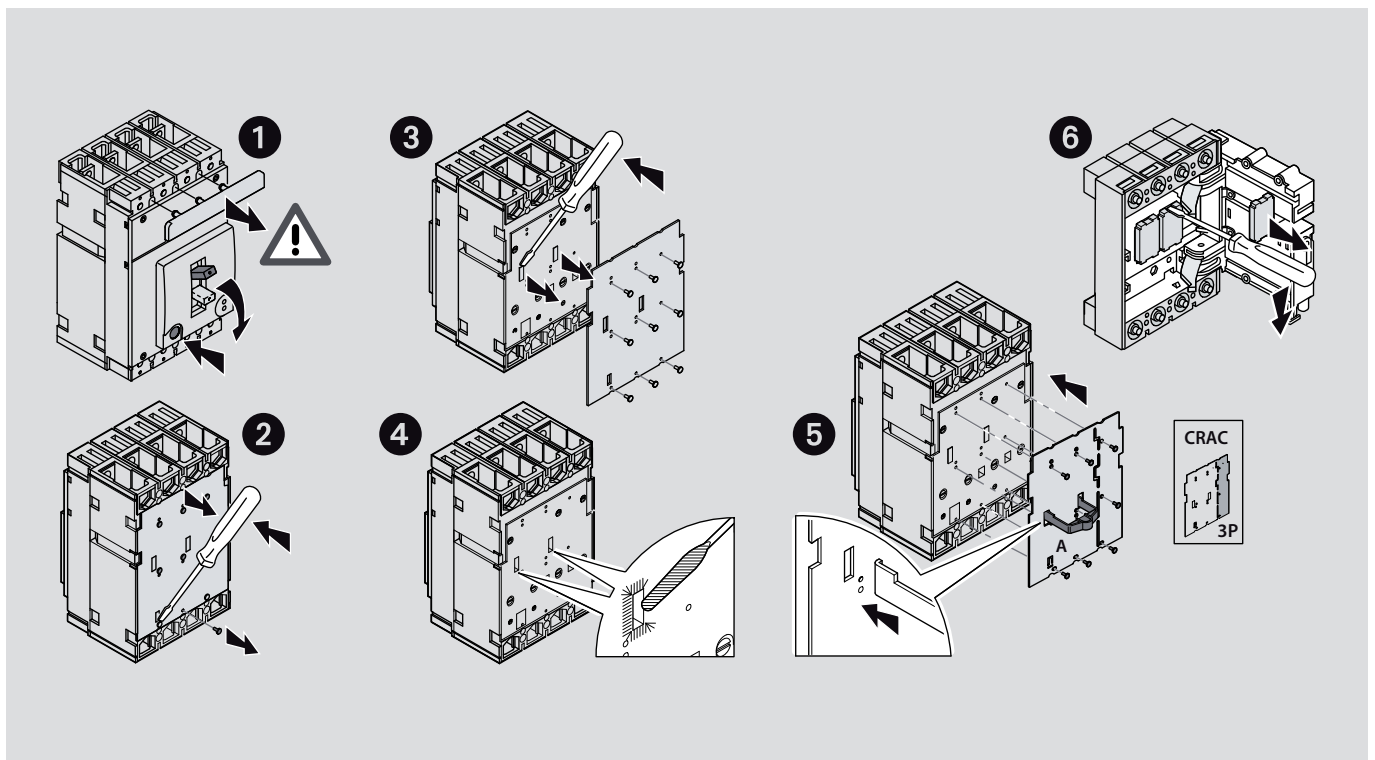

Set up the mechanical interlock according to the illustrations below:

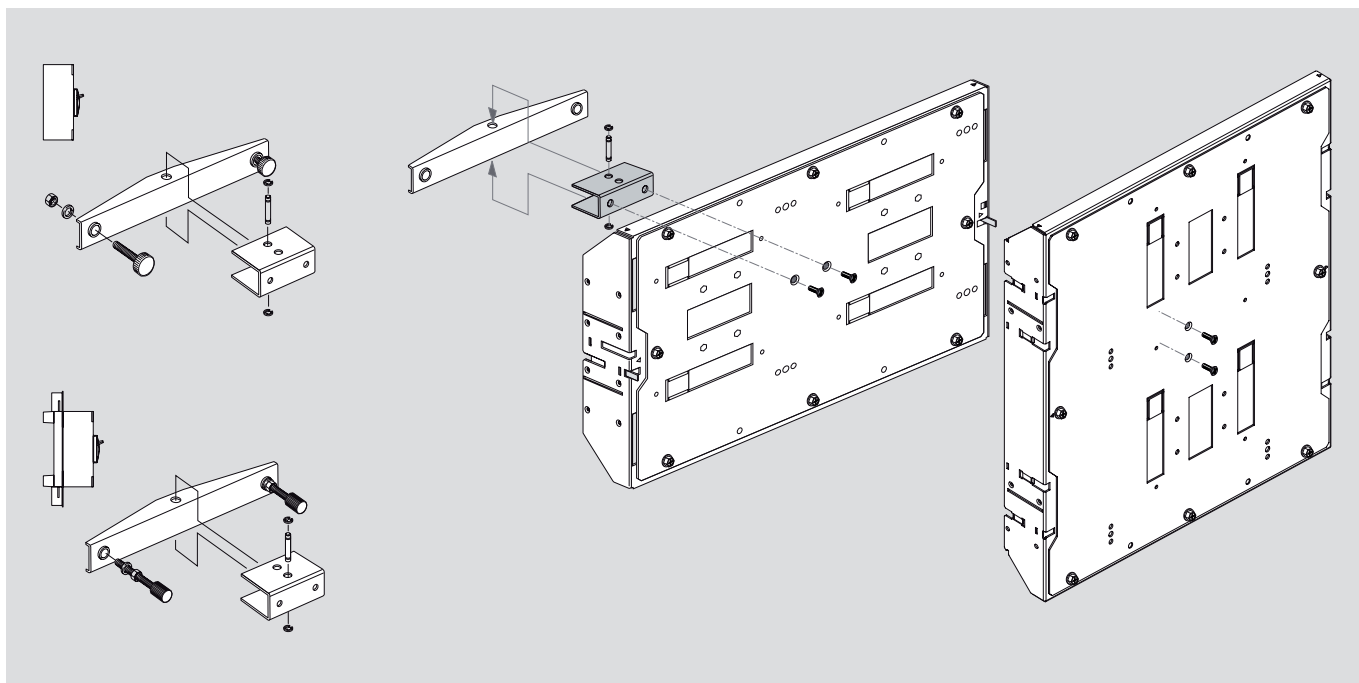

Points to check and settings:

- Check that the U-shaped parts mounted on the circuit breakers slide freely without any special effort. If not, check that the cutout is done correctly.
- Load the spring manually on the 2 devices (Q1 and Q2) and close Q1.
- Adjust the wide head screw so that it has the same length, touch the U-piece on the Q1 side, and adjust (Q2 side) the distance between the screw head and the U-piece (distance between 0.5 and 1 mm).
- Open Q1, load the spring, then close Q2.
- Repeat the same operation for Q1 (distance).



These adjustment operations are identical for the fixed, plugged-in and draw-out versions.

DPX³ 630 electrical accessories

■ **Auxiliary fault signalling contact**

- 4 210 11

■ **Shunt releases**

- 4 222 39 24V AC/DC
 - 4 222 40 48V AC/DC
 - 4 222 41 110V AC/DC
 - 4 222 42 230V AC/DC
 - 4 222 43 400V AC/DC

■ **Undervoltage releases**

- 4 222 44 24V DC
 - 4 222 45 24V AC
 - 4 222 46 48V DC
 - 4 222 47 110V AC
 - 4 222 48 230V AC
 - 4 222 49 400V AC
 (power supply included)

■ **Time-lag modules**

- 0 261 90 230V AC
 or
 - 0 261 91 400V AC
 +
 - 4 226 23 UVR

■ **Batteries for DPX³**

- 4 210 82 2 CR1616 batteries for one circuit breaker+ supports

■ **Motor-driven handle (front installation)**

- 0 261 40 24V AC/DC
 - 0 261 41 48V AC/DC
 - 0 261 42 110V AC
 - 0 261 44 230V AC
 - 0 261 48 220-250V DC
 - 4 226 26 110-125V DC
 - 4 226 30 230V AC (standard)

■ **Locking for motor-driven handle**

- 0 261 58 star key
 - 0 261 59 flat key

■ **External power supply**

- 4 210 83 24V AC/DC - 250 mA

■ **Set of connectors - 8 contacts (rear installation)**

- 0 263 99 for plugged-in and debracket versions

■ **Set of connectors - 6 contacts (rear installation)**

- 0 098 19 for plugged-in and debracket versions

■ **Set of connectors - 24 contacts (lateral installation)**

- 4 222 29

■ **Signalling contact**

- 0 265 74 plugged-in/draw-out

■ **Set of contacts (12) (lateral installation)**

- 4 222 30 for draw-out version

■ **Electronic earth leakage modules**

- 0 260 60 standard 3P 400A
 - 0 260 61 standard 4P 400A
 - 0 260 63 LED 4P 400A
 - 0 260 64 standard 3P 630A
 - 0 260 65 standard 4P 630A
 - 0 260 67 LED 4P 630A

■ **Communication interface modbus**

- 4 210 75

1 AUXILIARY FAULT SIGNALLING CONTACT (OC/CTR, CAT.NO 4 210 11)



All DPX³ circuit breakers and switches can be equipped with electrical auxiliaries to ensure control functions.

The auxiliary contact Cat.no 4 210 11 is common to the entire DPX³ range.

Depending on its insertion position in the DPX³, the contact acts either as an auxiliary contact or as a fault signalling contact.

The auxiliary contact (OC) allows the signaling of the position of the main contacts of the circuit breaker or switch (open or closed).

It is neither anticipated nor delayed.

The fault signalling contact (CTR) indicates that the circuit breaker has opened on fault, per action of a trigger, by a draw-out operation or by mechanical action on the Red "test" button.

These contacts are of the changeover type (NO-NC) with dry contact (potential free).

Setting up the OC contact

- Press the Red "test" button to trigger the product and have the handle in the intermediate position.
- Remove the 4 screws from the product cover

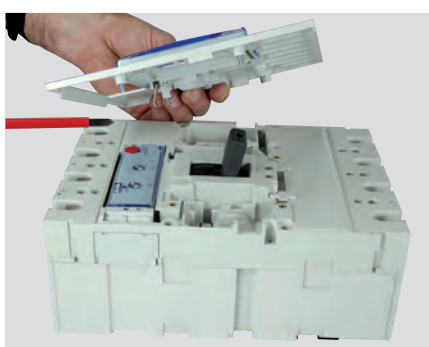

- If the OC contact

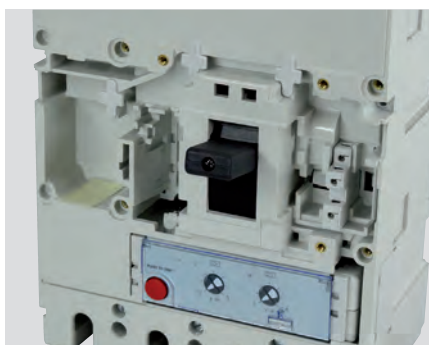
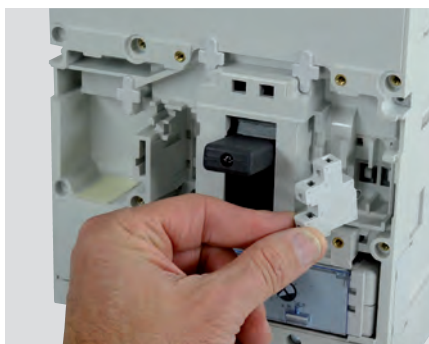

! Its location is dedicated (possibility to put 2 OC Max. on the DPX³ 630).

OC contact presentation :

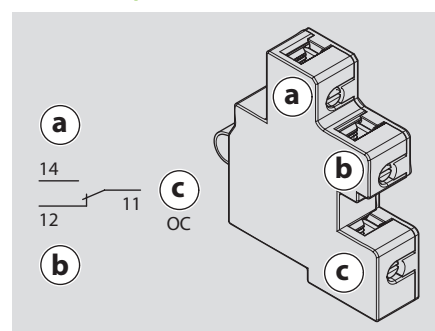

OC contact status:

	OC	12 - 11	14 - 11
OFF			
Triggered			
ON			

CTR contact presentation :

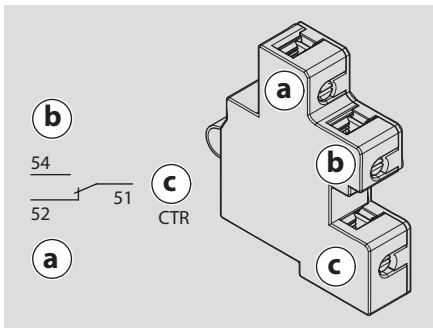

- Insert the CTR contact (only 1 possible location):

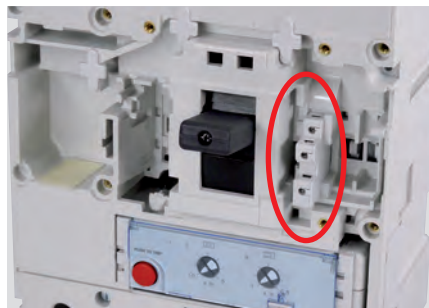

2 SHUNT RELEASES (EXAMPLE CAT.NO 4 222 42)



CTR contact status :

CTR	52 - 51	54 - 51
OFF		
Triggered		
ON		

Electrical characteristics (IC & CTR)

VOLTAGE	CURRENT (A)	
	RESISTIVE LOAD	INDUCTIVE LOAD
24 Vdc	10	5
48 Vdc	1.3	0.7
110 Vdc	0.4	0.3
230 Vdc	0.3	0.2
110 Vac	10	4
230 Vac	6	2

Shunt releases allow the instantaneous opening ($\leq 50\text{ms}$) of the device by the power of their coil: external contact control NO.

The contact incorporated into the shunt release switch shuts off the power supply during an opening control (e.g., emergency stop), thus avoiding the heating problem. The permanent supply of the shunt release is possible, prohibiting the closure of the DPX³.

Setting up the fault signaling contact

- Press the Red "test" button to trigger the product and to have the handle in the intermediate position.
- Remove the 4 screws from the product cover.

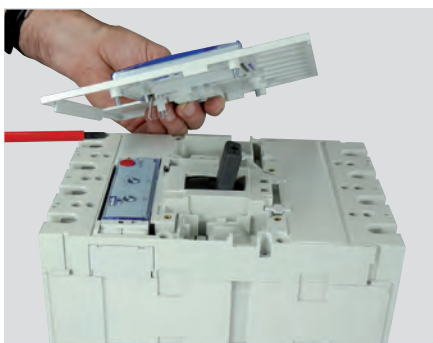

OC and CTR cabling :

The wires must be pulled out on the side of the circuit breaker, the permissible section extends from 0.35 mm^2 to 1.5 mm^2 . In the case where several OC and CTR contacts are present, the recommended section is 0.50 mm^2 .

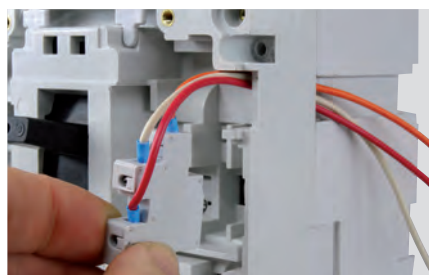

Electrical characteristics

OPERATING VOLTAGE	AC : 24V/110V/ 230V/400V DC : 24V/48V
Operating range IEC 60947-2	70 to 110% Un
Operating time	$\leq 50 \text{ ms}$
Inrush power	300 VA/W
Request time	$> 50 \text{ ms}$
Insulation voltage	2,5 kV

■ Setting up

A single location is provided for mounting regardless of the product of the DPX³ 630 range.

These triggers are mounted to the left hand side of the product (front view).

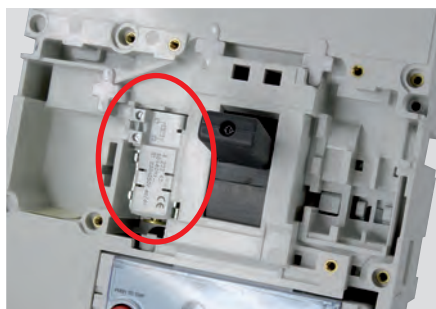

■ Connection – cable output

Only one output is possible: lateral output.



The accessory Cat.no 9 803 86 can be used to maintain the cables in place:



3 UNDERVOLTAGE RELEASES (EXAMPLE CAT.NO 4 222 48)



The undervoltage release allows the instantaneous opening (≤ 50 ms) of the device by switching off the power supply ($< 85\%$ UN) of the coil: positive safety (e.g. emergency stop by external contact NF).

The undervoltage release must be pre-energized before putting the associated DPX³ in the rearming position (OFF) to reset the product.

Electrical characteristics

OPERATING VOLTAGE	AC : 24V/110V/ 230V/400V DC : 24V/48V
Operating range IEC 60947-2	85 to 110% Un
Operating time	< 50 ms
Holding power	1.6 W / 5 VA

■ Setting up

A single location is provided for mounting regardless of the product of the DPX³ 630 range.

These triggers are mounted to the left of the product (front view).

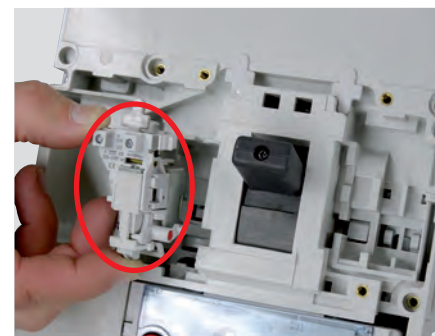

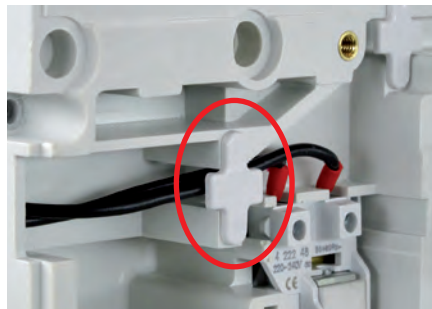
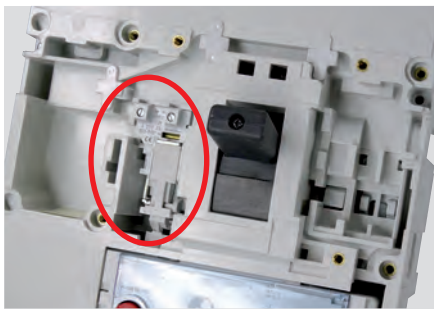

Cat.no 4 210 82 composition : 2 batteries CR1616 + two battery holders (1 for DPX³ 160/250 and 1 for DPX³ 630/1600).

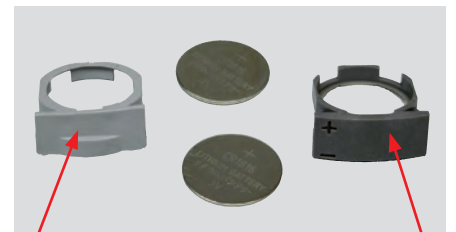

Holder for DPX³ 160/250

Holder for DPX³ 630/1600

■ **Connection – cable output**

Only one output is possible: lateral output.

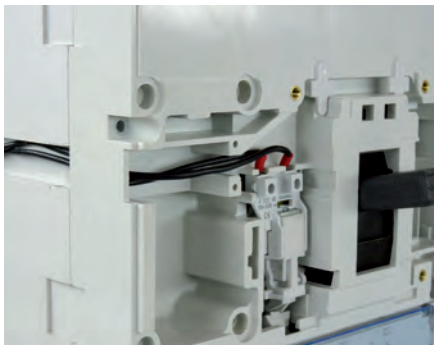

4 800 MS TIME-LAG MODULES

- 0 261 90 : voltage 230 VAC (supplied with 2 terminal covers and 1 rail)
- 0 261 91 : voltage 400 VAC (supplied with 2 terminal covers and 1 rail)
- 4 226 23 : specific trigger to be associated with Cat.no 0 261 90 or Cat.no 0 261 91 according to the desired voltage.

The wiring is done in parallel.

Example :

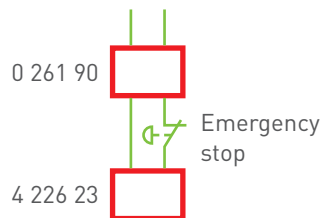

The accessory Cat.no 9 803 86 can be used to maintain the cables in place:



■ **Setting up**

- Remove the battery holder using a small flat screwdriver and place the 2 batteries with the "+" upwards :



- Insert the whole into the product and set the protection unit.



5 BATTERY FOR DPX³ CAT.NO 4 210 82

The internal battery allows the protection unit of the differential and electronic DPX³ to be set before installing the product.

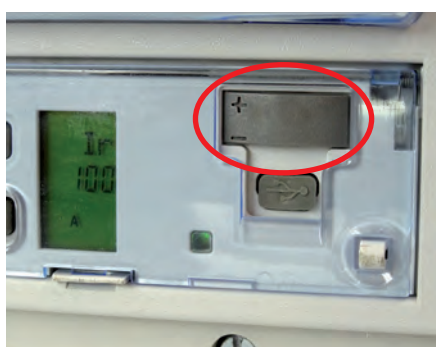

6 MOTOR-DRIVEN HANDLE

The motor-driven handle of the DPX³ 630 offers a significant advantage in all commercial building installations, it allows to close or open a circuit breaker or a remote switch. When used in automatic transfer switch, its control is managed using the automation box.

The front panel has a controller to charge the spring, a status indicator of the "loaded" or "unloaded" spring, a multifunction selector (auto-man lock), a closing button, an opening button and a locking device.

It is available in several voltages:

AC → 24 V/48 V/110 V/230 V

DC → 24 V/48 V/110 V-125 V /220-250 V

It is only available in front version → no side version. 2 possibilities of electric controls: impulse or sustained.

In automatic mode, the motorized control allows to open, close or remotely rearm the DPX³.

In manual mode, electrical orders are not taken into account. The front handle allows you to load the spring manually and then close the associated device. To open the device press the red button.

In locked mode, it is not possible to drive the motorized control electrically or manually. This mode is only possible when the DPX³ is in the open position "0".

It is possible to fit them with a key lock (Cat.no 0 261 58/59) or 1 or more padlocks (quantity: 3 Maxi. diameter 6 mm Maxi, for example with padlock Cat.no 0 227 97), prohibiting the closing of the DPX³ and the cancellation of all the electrical orders.

For the safety of persons and equipment, when the motorized control cover is removed, a safety contact makes it ineffective to operate.

In the case of the use of a transfer switch, the switching time between the main line and the backup line (time between the opening of the main line and the closure of the backup line) is greater than or equal to 6s.

There are 2 versions of motorized control: a premium version and a standard version.

Presentation and composition of the premium version (0 261 40/41/42/44/48 and 4 226 26) :



Presentation and composition of the standard version (4 226 30 only) :



Premium version :

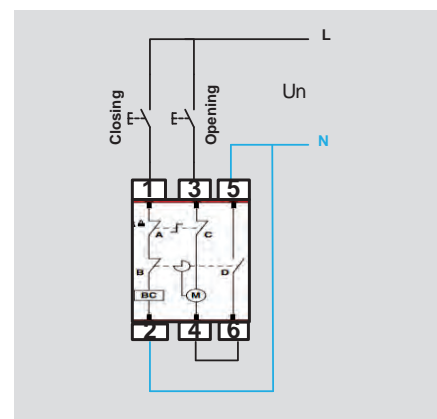

Standard version :

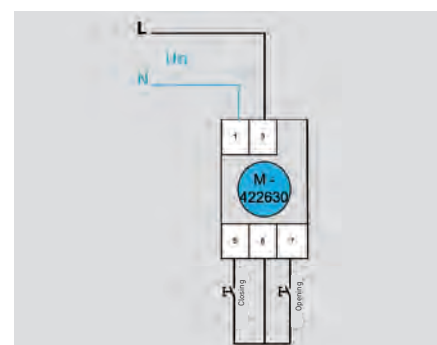

Electrical characteristics of the premium version :

Voltages – Un (V)	Power consumption	Opening + rearming ⁽¹⁾	Closing ⁽¹⁾
24 Vdc	300 W	2s	≤ 100ms
48 Vdc	300 W	2s	≤ 100ms
24 Vac	300 VA	2s	≤ 100ms
48 Vac	300 VA	2s	≤ 100ms
110 Vac	300 VA	2s	≤ 100ms
230 Vac	300 VA	2s	≤ 100ms

(1) provided that these voltages/powers conform to the specifications given.

Electrical characteristics of the standard version :

In the case of the use of a transfer switch, the switching time between the main line and the backup line (time between the opening of the main line and the closure of the backup line) is greater than 6s motor alone without accessories.

Voltages – Un (V)	230 VAC – 50/60 Hz	
	Opening	Closing
Inrush current	240 W	200 W
Hold consumption	80 W	120 W
Request time/electrical operation(s)	0.45 s	0.55 s
Operating time/main contacts state change	0.27 s	0.55 s

■ Mounting (same for 2 versions)

i It is forbidden to remove the protective cover in operating mode. This operation will result in an inhibition of the electrical function (internal safety contact).

Function of the markers :

The reference part G is a delay of the OFF button of the motor. In the absence of this part, it is not possible to mechanically open the associated device using the OFF button (trigger button).

The reference part H is an axis to position the carry-over of the OFF button on the cover.

Part D is a power connector.

Part C is an associated device power contact position (from the I/O front panel indicator).

Screws B and F are fastening screws.

The reference part E is an XL³ faceplate power terminal cover.

- Make the two cuts (they must be made in a very clean way, in case of large burr, they will prevent the correct sliding of the status report), then drill the holes as indicated in the installation instructions.



- Place the metal bracket and its axle (toothed part towards the handle) in the intended housing. The bracket must be free in its movement. Any improper implementation will result in the inability to open the associated device via the OFF button in manual mode.





- Reposition the DPX³ cover.



- Set up the 4 screws for securing the motorized control (tightening torque 2 N. m), then place the motor cover using the 2 screws supplied (tightening torque 1 N. m).
- Perform a few closing and opening operations manually (attention the function selector must be on MAN) in order to check the correct mechanical functioning of the whole.

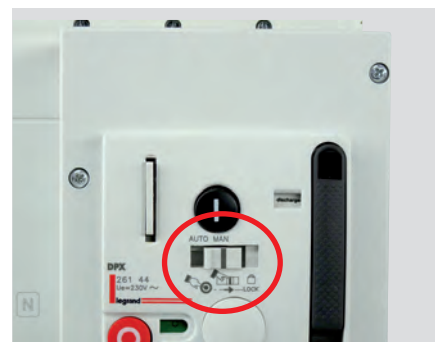

- Set up the status report. It follows the movement of the circuit breaker mechanism (I - 0).



- Remove the protective cover from the motorized control and position it by being vigilant on the insertion position of the circuit breaker handle.



■ Visual and operating differences :

Premium version:

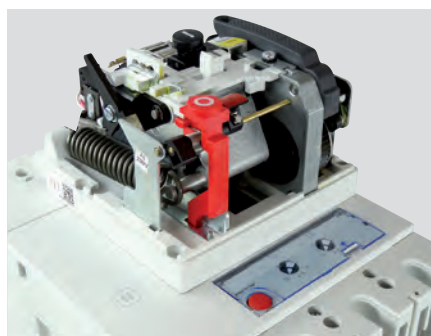

Standard version:



Hole for manual opening/closing

- The push button is no longer present on the standard version.
- Absence of the spring reload lever and the status display on the standard version.
- Presence of an orifice (passage of an 8 mm Allen wrench supplied) in case of manual reset.

As the standard version motor drive has no loading spring, the mechanical opening/closing test is always carried out in manual position but only by using the supplied tool (8 mm Allen wrench) in the intended orifice (direction time → closing the DPX³, counterclockwise → open/reset).

Illustration photo for mechanical operations on the standard version :



7 LOCKING ACCESSORIES FOR MOTOR DRIVE

There are two possibilities to lock the motor drive :

- By padlock, the maximum number is 3 of 6 mm maximum. Example with a padlock Cat.no 0 227 97 :



- By lock Cat.no 0 261 59 (flat key) or Cat.no 0 261 58 (star key).

■ Example of mounting the Cat.no 0 261 59

1. Composition



2. Remove the protective cover.



3. Drill 2 holes (3 mm) using the drill jig provided.



4. Fasten the square piece from the rear using the 2 screws provided (tightening torque 2 N. m) .



5. Insert the key barrel and fasten it using the supplied nut (tightening torque 2 N. m).



6. Horizontal key position → the key cannot be removed, and the motor is not locked.



7. Position of the vertical key with the red button "0" pressed → the key can be removed, and the motor is locked.

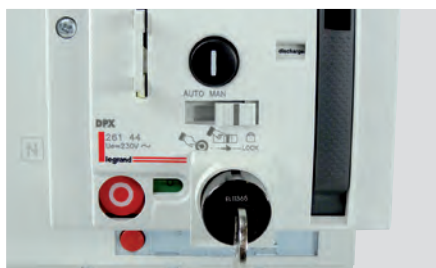

i To lock, it is necessary to press the red button "0" then turn the key in the vertical position. To unlock, press the red button "0" and turn the key to the horizontal position.

8 EXTERNAL POWER SUPPLY (CAT.NO 4 210 83)



It allows the DPX³ electronic units to be supplied when the circuit breaker is not energized or when the current passing through it is insufficient. It also provides power to several circuit breakers (maximum output 250 mA). Sidewalls with a specific connector are provided and connected to the side of the circuit breakers.



i Warning, the electronic circuit breakers DPX³ 630 type S1 do not allow the addition of an external power supply.

9 SET OF CONNECTORS (CAT.NO 0 098 19 & 0 263 99) → REAR INSTALLATION

See the details of the installation in the "mechanical accessories" section (plug-in/debro-lift). The process is also illustrated in the installation instructions of the Cat.no 4 222 31/32/33.

It is not possible to install these connectors in the case of products mounted using a transfer switch.

10 SET OF CONNECTORS FOR PLUGGED-IN VERSION (CAT.NO 4 222 29) → SIDE INSTALLATION

This catalogue number is composed of 2 male/female connectors of 12 terminals each (24 terminals in total) allowing the connection of the accessories (OC - CTR - motor drive - coils).

It is only available in the international catalog.



The whole is carried out by following the steps of the installation instructions (supplied with the product but also available on the instructions of the base Cat.nos 4 222 22/23/24/25/26/27) in accordance with the following point :

- Leave a necessary length of wires coming out of the product (triggers, OC/CTR, etc...) → 13 cm.

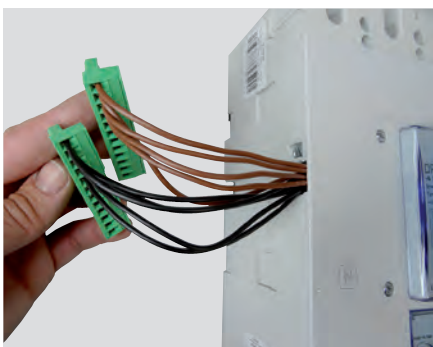
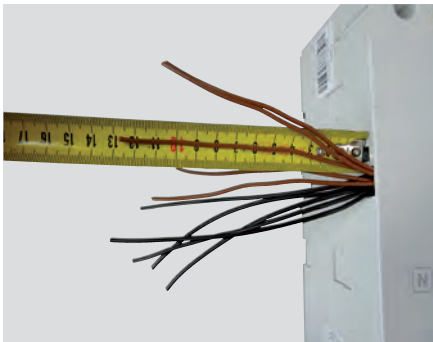

Final mounting :

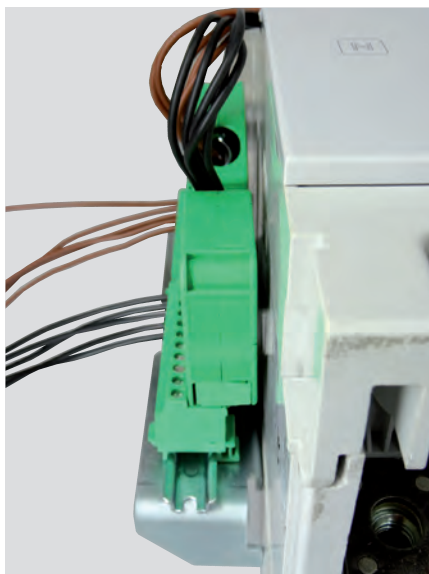
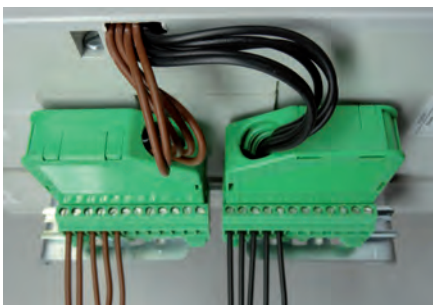

Marking is possible thanks to the orange part and the marking plate (numbers) supplied (for the green connectors terminals) :

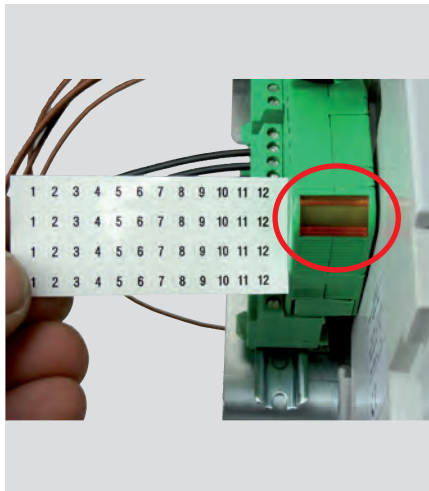

The different cable sections as well as the location recommendations of the wires are indicated on the instruction sheet according to the accessories present.

11 **SIGNALLING CONTACT PLUGGED-IN/DRAW-OUT-DEBRO-LIFT MECHANISM (CAT.NO 0 265 74)**

This contact is inserted into the base for a plugged-in or draw-out version.



First, the metal wedge must be screwed with the screw (these 2 parts are supplied) :

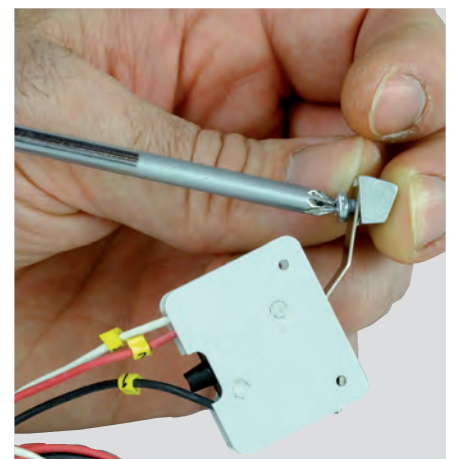

Then pass the contact wires in the dedicated hole of the base and insert the contact:

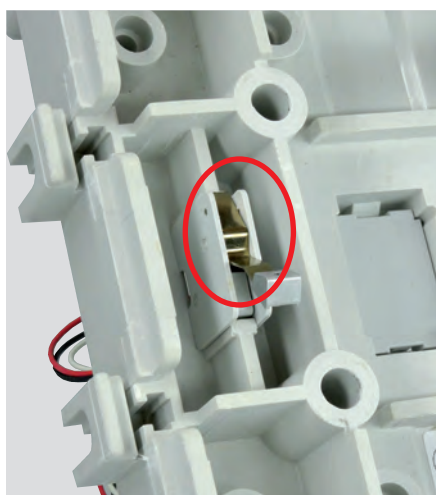
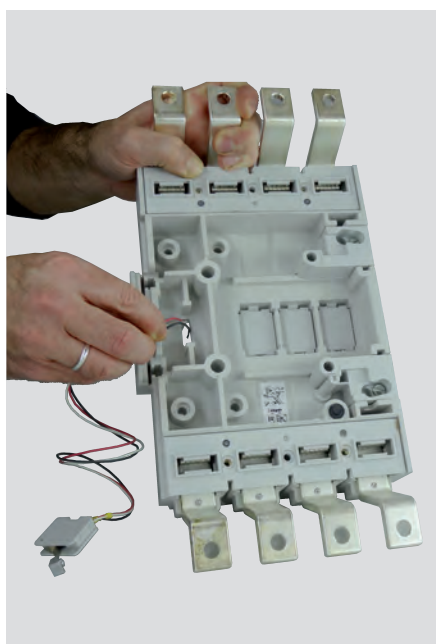

12 AUTOMATIC AUXILIARY CONTACT (CAT.NO 4 222 30)

This Cat.no is composed of 4 contacts of 3 terminals each. We can install up to 8 contacts per DPX³ (2 Cat.nos to order). These contacts are positioned on the side of the associated device. They can be on a product alone but also on 2 products for automatic transfer switch configuration.

Composition of the catalogue number :

In addition to the parts composing the Cat.no, others are necessary to complete the assembly. They are supplied with the base and the debro-lift mechanism :

Necessary parts in the base (Cat.nos 4 222 22/23/24/25/26/27): J, K and L marks.

Necessary parts in the debro-lift mechanism (Cat.nos 4 222 31/32/33): T and U marks.

The mounting is detailed on the instruction sheet of the base (for the female part of the contacts) and the debro-lift mechanism (for the male part of the contacts).

The different cable sections as well as the position of the wires are indicated on the instruction sheet according to the accessories.

LEAKAGE MODULE

An earth leakage module is a measuring device, usually associated with a circuit breaker, but can be a switch. It detects a current difference between the active conductors of an installation and initiates an action when the threshold is reached or crossed.

It is mounted downstream the MCCB.



- Press the Red mechanical test button
- Join the earth leakage module and the DPX³ and block the 4 screws (or 3 - tripolar) according to the tightening torque indicated in the instruction sheet → 24 N. m.



13 ELECTRONIC EARTH



Flat flexible bars, cables or cable with rings can be set up in the downstream terminal blocks of the earth leakage module.

- **Flat bars** : maximum width 32 mm, the center of the hole for the screw passage must be in the middle of the width of the bar and at a maximum of 16 mm from its end. The diameter of this hole is 11 mm. The tightening torque of the screws is 24 N.m.
- **Cables** : maximum diameter 26 mm (bare and without insulation). For installation, the cage terminals Cat.no 0 262 50 must be ordered. The tightening torque of the screws of the cage terminals is 24 N. m.
- **Cables with ferrule** : maximum width 32 mm. The diameter of the ferrule hole must be 11 mm. It is forbidden to put 2 ferrules on each other in the same terminal. The tightening torque of the screws is 24 N. m.

Several checks are required to verify the correct functioning :

Assembly verification :

Put the DPX³ in position "I" and then position the earth leakage module slider on "0".

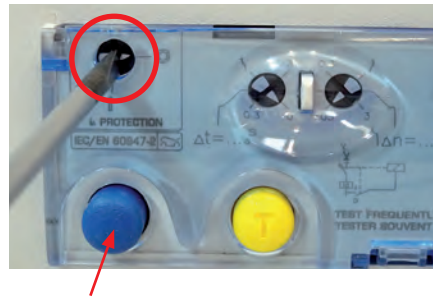

The blue reset button must be released and the DPX³ handle must move to the intermediate position. In this case, the operation is correct. In this configuration, you are not supposed to be able to move the DPX³ handle on "0" position.

Checking the possibility of rearming :

Position the earth leakage module slider to "I" and then push the blue reset button. If you can switch the DPX³ handle on the "0" position and then on "I", the operation is correct.



Blue button pressed

Check of the earth leakage tripping :

This operation must be performed under voltage. When pressing the yellow test button with the DPX³ in the "I" position, the blue button must extend, and the product must be placed on the intermediate position.

It is possible to remotely view the tripping on an earth leakage fault. You simply need to connect a LED on the 2 terminals located on the side of the earth leakage module :



1. Plugged-in version :

- 4 222 22 → Front terminal mounting base - for DPX³ only - 3P
- 4 222 24 → Flat rear terminal mounting base - for DPX³ only - 3P

14 COMMUNICATION INTERFACE MODBUS (CAT.NO 4 210 75)

The Cat.no 4 210 75 interface allows to connect certain Legrand products such as DPX³, adaptable earth leakage modules, on a MODBUS RS485 communication network.

It is equipped with a contact indicating the triggered status of the associated circuit breaker.



CHARACTERISTICS

- RS485 communication interface for DPX³ and adaptive earth leakage module.
- 24 V DC/AC power supply use double galvanic isolation or equivalent power supply, example of Cat.no 1 466 23.
- Consumption 90 mA.
- RS485 communication port.
- Modbus settings by jumpers.
- Free-of-potential contact for status information - tripped circuit breaker Max 220 V 0.2 A.

PRODUCT SELECTION

Cat.no 4 210 75 communication interface must be used with communicating DPX³ and adaptive earth leakage modules.

CONNECTION

■ Link between Cat.no 4 210 75 interface and the Legrand product



Connection under the communication interface. The link cord is supplied with the interface.

i The length of the cord supplied with the interface Cat.no 4 210 75 is 0.70 m.

■ Interface power supply

- Power supply 24 V DC / AC.
- Use a double galvanic insulation or equivalent power supply.
- Connection by connector.



The communication interface Cat.no 4 210 75 must be protected as any electrical circuit.

■ Using the status contact

- The information of the tripped status of the circuit breaker is present on a potential free contact.
- NF = tripped circuit breaker
- Push button function, relay test, support = NF
- Connection by connector.

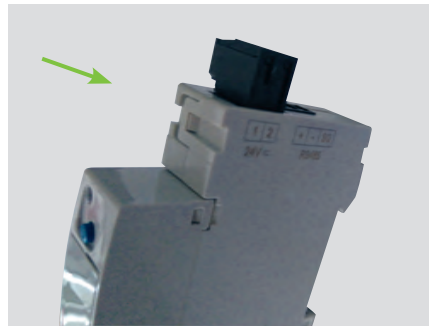

■ Connection to the RS485 BUS

- Connection of the interface to RS485 BUS.
- The wiring principle of a RS485 BUS is detailed in the chapter "communication protocols".
- Connection by connectors.

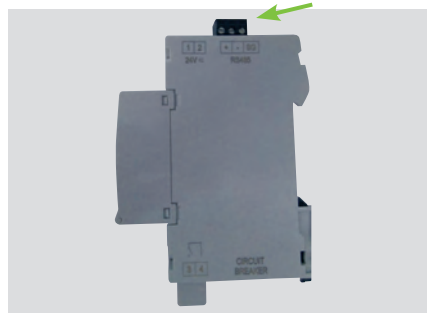
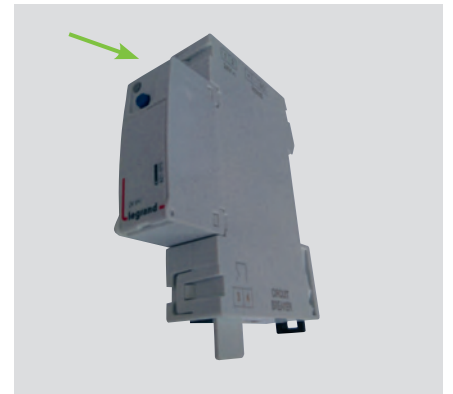

SETTING

Setting of the communication interface Cat.no 4 210 75 is done via jumpers.

- A1 / A2 / A3 : Modbus address.
- M : Modbus transmission mode (RTU / ASCII, parity, stop bit).
- B : transmission speed.
- Jumper 6 : not used.

The setup details are shown in the datasheet.

Configuration jumpers are available under the catalogue numbers: :

- Complete kit from 0 to 9: Cat.no 3501K (10 of each).
- Set of 10 individual jumpers: Cat.no 3501/X (example reference 3501/1 = set of 10 jumpers-1).

DATA RETURN AND MODBUS ADDRESSING

The Cat.no 4 210 75 remains a communication interface for transcribing the information present on the Legrand circuit breakers in Modbus RS485 Protocol. The different register tables are available in the "product data" paragraphs of the DPX³ and adaptable earth leakage modules.



DPX³ 630 mechanical accessories

■ **DPX³ base - plugged-in version**

- 4 222 22 Front terminal - 3P
- 4 222 23 Front terminal - 4P
- 4 222 24 Flat rear terminal - 3P
- 4 222 25 Flat rear terminal - 4P
- 4 222 26 Flat rear terminal - 3P
- 4 222 27 Flat rear terminal - 4P with earth leakage modules

■ **Terminals for plugged-in/draw-out version**

- 4 222 20 for DPX³ 3P
- 4 222 21 for DPX³ 4P

■ **Set of 2 extractor handles**

- 4 222 28 (plug-in version only)
- 4 222 31 for DPX³ 3P
- 4 222 32 for DPX³ 4P
- 4 222 33 for DPX³ 4P + earth leakage module

■ **Insulated handle for drawing-out**

- 0 265 75

■ **Debro-lift – locking system**

- 0 265 76 flat key
- 0 263 48 star key
- 0 265 77 star key motorised/with rotary handle

- 0 265 78 flat key motorised/with rotary handle

■ **Universal plates for transfer switch**

- 0 264 04 for for plug-in, draw-out
- 0 264 09 for fixed version

■ **Rotary handle**

- 0 262 41 standard (black)
- 4 222 38 emergency (red & yellow)

■ **Remote rotary handle**

- 0 262 81 standard (black)
- 0 262 82 emergency (red & yellow)

■ **Lock for remote rotary handle**

- 0 262 92 eurolock key
- 0 262 93 star key
- 0 262 94 flat key
- 4 228 04 key barrel and Ronis key
- 4 228 05 key barrel and Ronis key

■ **Locking accessory for direct rotary handle**

- 0 262 25

■ **Connection terminals**

- 0 262 50 300mm² rigid or 240 mm² Maxi. flexible → set of 4 terminals
- 0 262 51 2x240² rigid or 2x185² flexible → set of 4 terminals

■ **Flat rear socket set upstream and downstream**

- 0 263 52 3P
- 0 263 53 4P

■ **Set of 4 connectors for terminals**

- 0 262 46

■ **Set of 4 DPX extended front terminals**

- 0 262 47

■ **Incoming and outgoing spreader**

- 0 262 48 3P
- 0 262 49 4P

■ **Set of 3 insulated shields**

- 0 262 30

■ **Set of 2 terminal shields**

- 0 262 44 3P
- 0 262 45 4P

■ **Padlock for DPX 630**

- 0 262 40

■ **Set of 2 sealable terminal covers**

- 4 222 34 for 3P
- 4 222 35 for 4P

■ **Plate for D/O version**

- 4 222 36

■ **Retrofit kit DPX 630 – DPX³ 630**

- 4 222 37

1 PLUG-IN VERSION

3P	4 222 22 → 3P base - front terminals	+	4 222 20 → 3P terminals
	4 222 24 → 3P base rear terminals		
4P	4 222 23 → 4P base front terminals		
	4 222 25 → 4P base-rear terminals	+	4 222 21 → 4P terminals
	4 222 26 → 4P base + e.l.c.b front terminals		
	4 222 27 → 4P base + e.l.c.b rear terminals		

■ Front/ rear terminal mounting base (4 222 22/23/24/25/26/27)

Composition (ex. Cat.no 4 222 23) :



2 SET OF INCOMING AND OUTGOING TERMINALS - PLUGGED-IN BASE 3P-4P (CAT.NO 4 222 20/21)

Composition (ex. Cat.no 4 222 21)



Trigger mechanism for plug-in and draw-out versions :

Plug-in or draw-out devices can be inserted or removed without powering down the system. Connection or disconnection operations (on or off) must be carried out with the devices in open position. However, in the case of unintentional extraction with a closed circuit breaker, the internal safety mechanism opens the unit at the first disconnection operation. This device prevents on-load disconnection of the DPX³.

- Remove the protection plate from the trigger mechanism at the back of the circuit breaker.

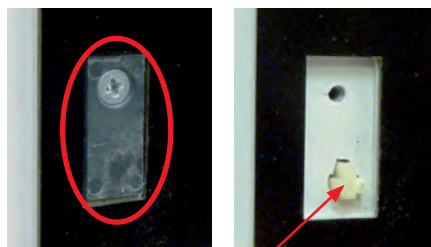

Push-button

- When removing the protection plate, the circuit breaker or switch triggers (if it is in the closed or open position). As a result, the handle is in the intermediate position → middle. To close the unit, the push button must be pressed. Then put the device in the open position and close it.

- Secure the metal plate (supplied with the set of terminals Cat.no 4 222 20 or 4 222 21) of the mobile connector bracket at the back of the circuit breaker using the 4 screws provided (tightening torque 1 N.m.). When using the connectors Cat.no 0 098 19 or 0 263 99, attach the male part of these connectors to the mounting brackets using the nut provided with these catalogue numbers. (tightening torque 1 N.m.):

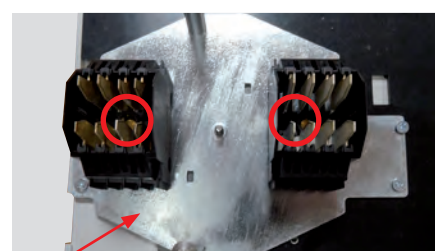
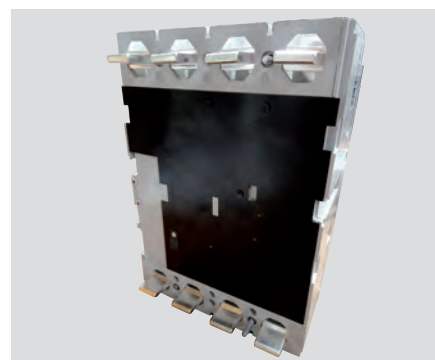
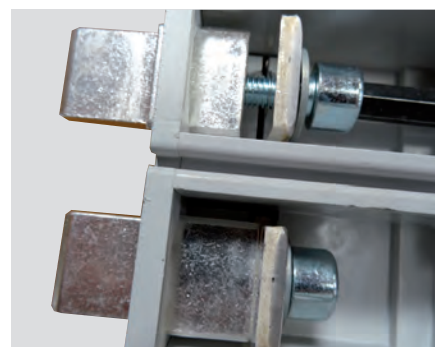

Plate – connectors Cat.no 0 263 99

The different cable sections as well as the position of the wires are indicated in the instruction sheet according to the accessories.

- Set up the upstream and downstream rear connections and use the supplied M8 screws (**without tightening them to put the protective covers in place without difficulty**).



- Put the protective covers, then tighten the screws to the recommended torque → 25 N.m.

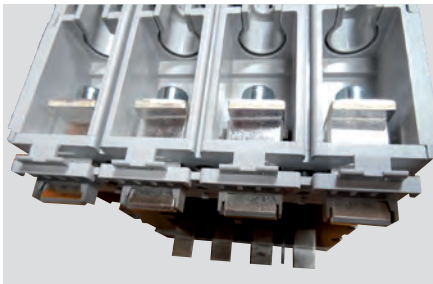

- Perform the required operations according to the terminal's instruction sheet (page 5) Cat.no 4 222 20/21, and put the terminal covers on the circuit breaker.
- When using the connectors Cat.no 0 098 19 or 0 263 99, remove the plastic part and clip the female part of these connectors in the dedicated place (3 slots available):

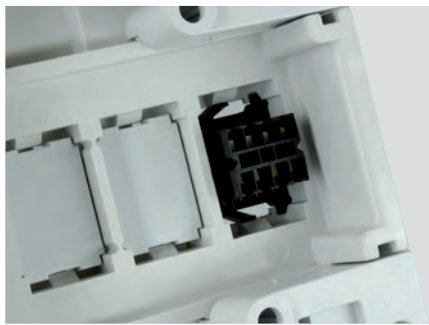

3 SET OF 2 EXTRACTOR HANDLES CAT.NO 4 222 28

These handles allow to extract the product and have a comfortable grip for its removal.

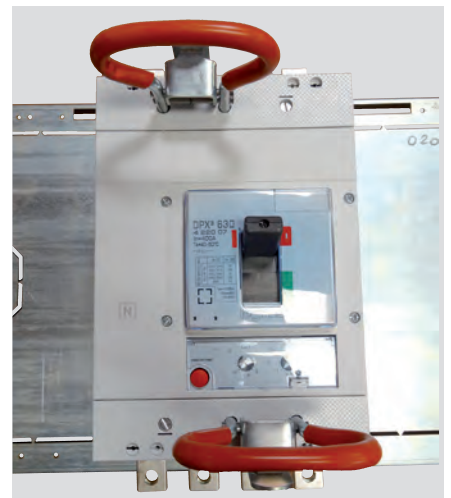

4 DRAW-OUT VERSION (DEBROLIFT)

The Debro-lift mechanism allows the operation of plugging or unplugging without removing the faceplate and holding the circuit breaker or switch in its base.

A draw-out version DPX³ is a plugged-in DPX³ (1 base + 1 set of terminals → see catalogue numbers in Chapter 1) equipped with a "debro-lift" mechanism →

- 4 222 31 (for DPX³ 630 3P base)
- 4 222 32 (for DPX³ 630 4P base)
- 4 222 33 (for DPX³ 630 4P base / e.l.c.b)

■ Mounting :

- Check that the circuit breaker is open by pressing the Red test button.
- Remove the nuts (upstream and downstream) and their brackets using a screwdriver.
- Fix the 4 inserts supplied as shown in the instructions :

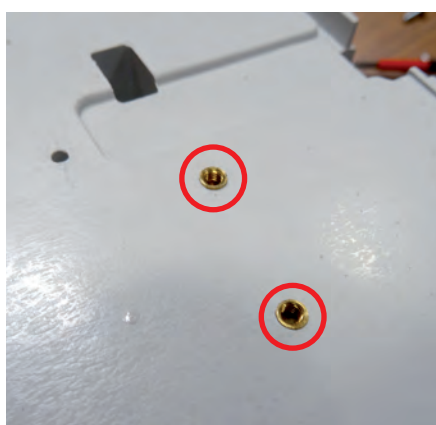

- Remove the protection plate from the trigger mechanism at the back of the circuit breaker :

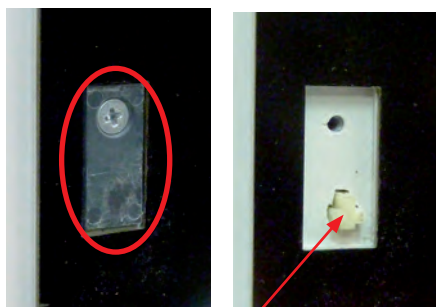

Push-button

- After removing the front face of the DPX³, attach the metal frame of the Debro-lift to the back of the circuit breaker using the 6 long screws provided. When using connectors Cat.no 0 098 19 or 0 263 99, the plate Cat.no 4 222 36 must be added at the rear of the frame using the 4 screws provided (tightening torque 2 N.m.) :

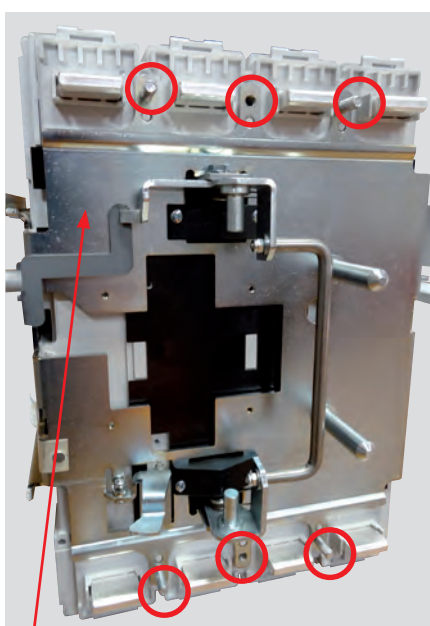

"Debro-lift" metal frame

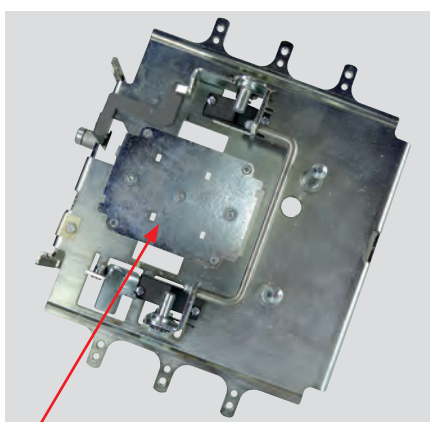
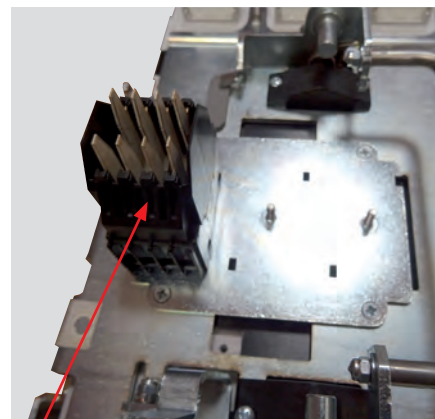

Plate Cat.no 4 222 36

- Then fasten the male part of these connectors to the studs of the plate (3 possible slots) using the nut supplied with the connectors Cat.no (tightening torque 1 N.m.) :



Cat.no 0 263 99

- On the base, place the part marked "I" in the instruction sheet using the 2 screws supplied with the "debro-lift" :

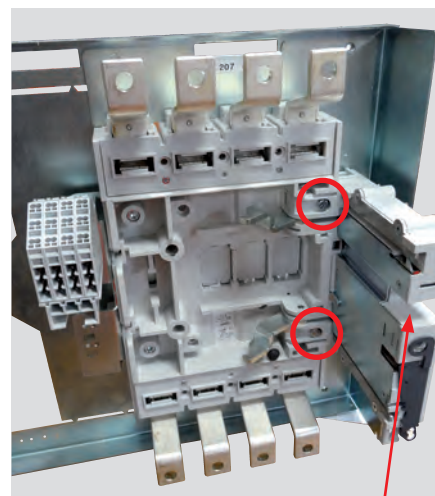

Part I on the instruction sheet

- Follow the installation of the last 2 parts as shown in the instructions.
- Assemble the upstream and downstream rear connections, terminal covers and the female part of the connectors Cat.no 0 098 19 or 0 263 99 (if present) as described above for the plug-in version.

5.1 FRONT LOCKING OF THE CIRCUIT BREAKER (CAT.NO 0 263 48 → STAR KEY/ 0 265 76 → FLAT KEY)

This accessory allows the product to be locked (non-motorized) in disconnected position → perform a consignment operation.

The product comes with a unique key. The assembly is detailed on the instruction sheet of the debro-lift mechanism (Cat.no 4 222 31/32/33).

Composition of the Cat.no 0 265 76 :

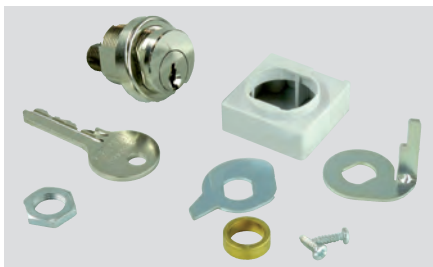

For the assembly, follow the steps of the instructions in accordance with the following points:

- At the beginning of the assembly, first remove the cover from the bracket :



- Check the correct positioning of the cam (at the back) :

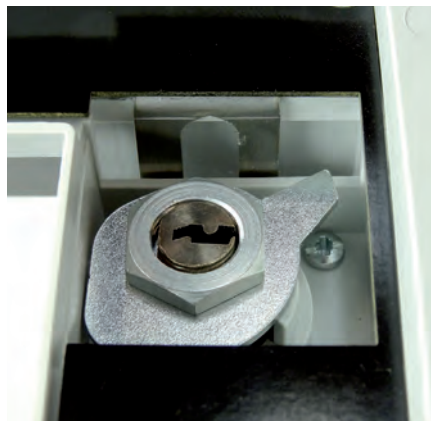

- Once the installation is done, check the operation of the key :

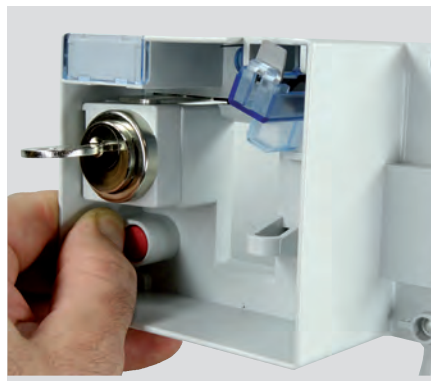

5.2 FRONT LOCKING (CAT.NOS 0 265 77 → STAR KEY/0 265 78 → FLAT KEY) → DPX³ MOTOR DRIVE OR ROTARY HANDLE

This accessory allows you to lock the product (motor drive or rotary handle) in disconnected position → perform a consignment operation.

The product comes with a unique key. The assembly is detailed in the instruction sheet of the debro-lift mechanism (Cat.no 4 222 31/32/33).

Composition of the Cat.no 0 265 78 :

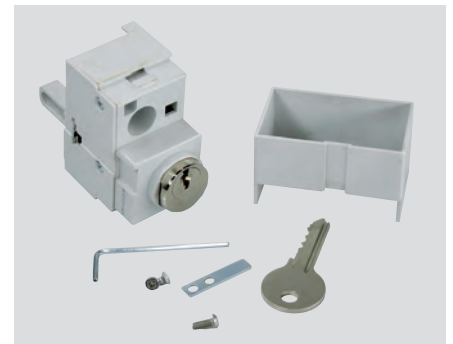

For the assembly, follow the steps in the instructions in accordance with the following points :

On the Debro-lift mechanism (movable part), fasten the metal plate (this part is used to prevent the locking in the connected position), in the holes provided :

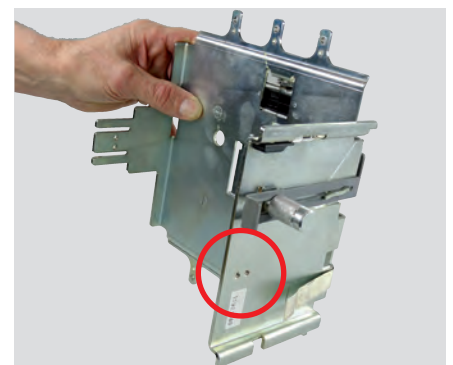



Put the locking block in the intended location, and tighten with the supplied screw :

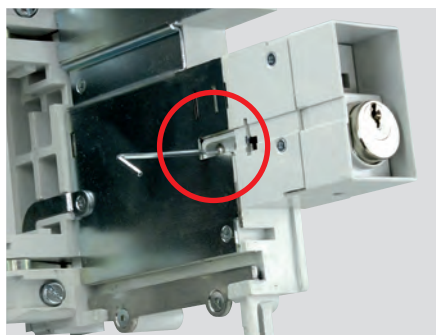
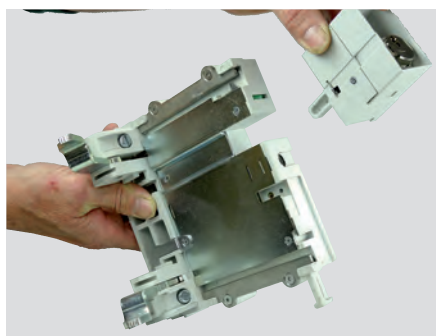

i It is possible to have the key number customizable with the company STI Montreuil (<http://www.servtrayvou.com/web/contact>) by giving the profile number: flat key N ° ABA90GEL6149 or star N ° HBA-90GPS6149.

6 ROTARY HANDLE (CAT.NO 0 262 41) OR EMERGENCY USE (CAT.NO 4 222 38)

Composition of the Cat.no 0 262 41 :



■ Mounting :

- Remove the circuit breaker cover by unscrewing the 4 screws, remove the transparent cover and drill three holes (diameter 4 mm) at the indicated locations :

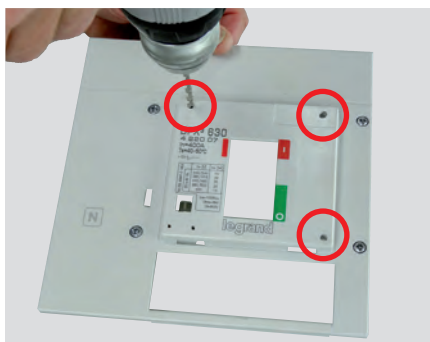

- Fasten the cover to the circuit breaker.



- Set up the frame (part E - instruction sheet) on the circuit breaker according to the photo and check that the frame is perfectly flush.



- Mount the mechanism on the circuit breaker, respecting the direction and then screw the whole with the screws provided, making sure that the protective tab is released (safety of opening - faceplate).

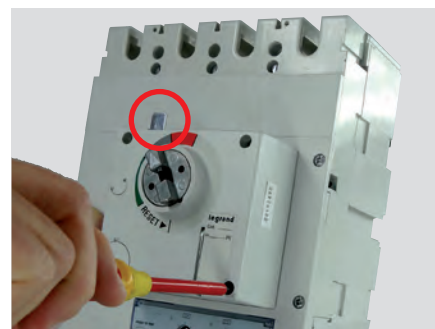

- Fix the handle in accordance with the locating pins and perform opening and closing operations, the tab must follow the movement (output in position "I" and entered in position "0")..



Locking :

- In the open position, you can use 3 padlocks (diameter 5 mm).



i With the key marked F in the instruction sheet, it is possible to open the faceplate while the device is closed (the key allows to fit the tab).

7 ROTARY HANDLE FOR VARI-DEPTH (CAT.NO 0 262 81) OR EMERGENCY USE (CAT.NO 02 62 82)

Composition of the Cat.no 0 262 81 :



Determine the length of the axis to be cut according to the information mentioned in the instruction sheet including the drilling to be carried out on the door :

- Total axis length = 290 mm, 8 mm x 8 mm square.

Padlock locking :

- In the open position, you can use 3 padlocks (diameter 5 mm).

8 LOCKING FOR ROTARY HANDLE CAT.NO 0 262 25

This accessory allows the DPX³ to be locked in the open position → perform a consignment operation.

Composition of the Cat.no 0 262 25 :



■ Mounting

- Handle in the "0" position before installation.
- Remove the plastic cover.



- Insert the Eurolock barrel in accordance with the following points :

- Place the wrench in the mechanism and position the whole 30 ° vertically.
- Lift the plate for the padlock slot with a screwdriver and insert the Eurolock barrel.

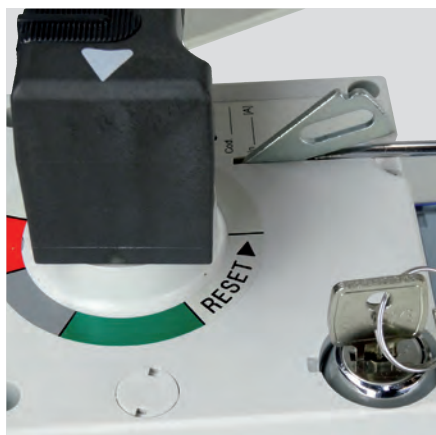

Handle in position "0": the key can be removed.



Handle in position "I": the key cannot be removed.



9 LOCKING ACCESSORY AND STAR KEY. 0 262 93/FLAT KEY CAT.NO 0 262 94 OR EUROLOCK KEY CAT. NO 0 262 92 OR CAT.NO 4 228 04/05

This accessory allows the DPX³ to be locked in the open position → perform a consignment operation.

Composition of the Cat.no 0 262 93



Proceed to the mounting as shown in the instruction sheet and check the correct operation of the whole: the key can be removed with the lever in position "0", it cannot work with the lever in position "I".



This lock can be combined with padlock (3 maximum from 5 mm to 8 mm).

Picture of the set mounted with the handle on "0" and the key removed :



■ Summary

- 0 262 93 : each reference comes with 1 single star key
- 0 262 94 : each reference includes 1 single flat key
- 4 228 04 : each reference includes 1 flat key EL 43525 common to all Cat.no 4 228 04
- 4 228 05 : each reference includes 1 flat key EL 43363 common to all Cat.no 4 228 05

**10 CAGE TERMINALS (X4)
CAT.NO 0 262 50**

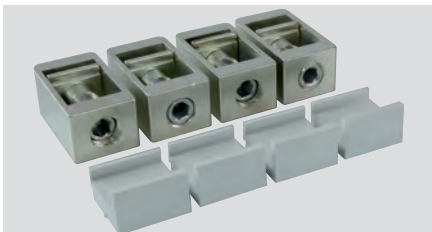

- Position the plastic part on the terminal as shown below.



- Insert the whole into the product.



- Repeat these operations for the other terminals.

The maximum diameter. of the cable to be used without its insulation is 26 mm, the tightening torque of the cable in the cage terminal is 24 N.m. The Maxi section. permissible by the cage terminal is 300 mm² (rigid cable) or 240 mm² (flexible cable).

**11 CAGE TERMINALS (X4)
CAT.NO 0 262 51**

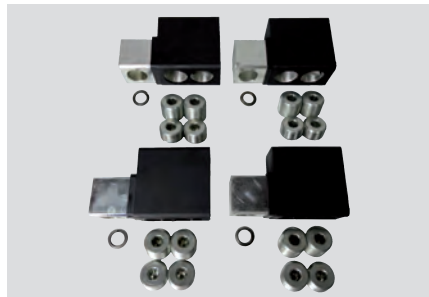

This terminal is commonly referred to as a large capacity cage terminal. The czt.no is supplied with 4 non-head screws – BTR type (length: 2x13 mm + 2x18 mm). The length of the screw to be used is different according to the section of the cable and the fact that it is rigid or flexible, see table below:

	X (13)	Y (18)
Flexible Conductors	120+185 mm ²	50+95 mm ²
Rigid Conductors	150+240 mm ²	70+120 mm ²

The maximum diameter. of the cable to be used without its insulation is 22 mm, the tightening torque of the cage terminal in the DPX³ is 24 N. m, the tightening torque of the cable in the large capacity cage terminal is 36 N.m.

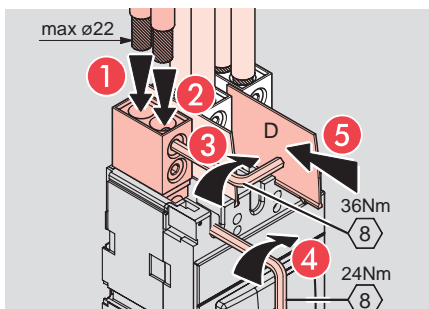

**12 REAR TERMINALS CAT.NO
0 263 52 (3P) & 0 263 53 (4P)**

This Cat.no makes it possible to turn a DPX³ front terminal into a rear terminal. It makes the connection easier.

Composition of the Cat.no 0 263 53



These terminals are adjustable by angle of 45°.

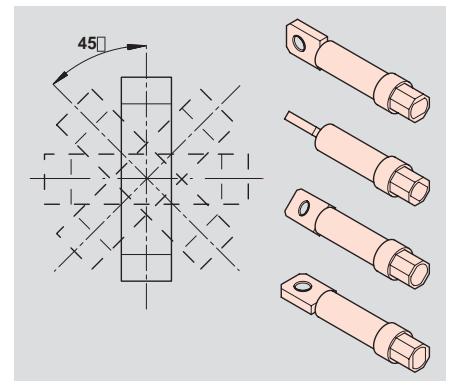

Setting up :

- Remove the nut holder + the breaker nut and then insert the brackets according below photos.

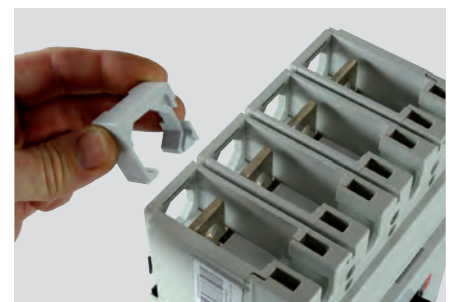

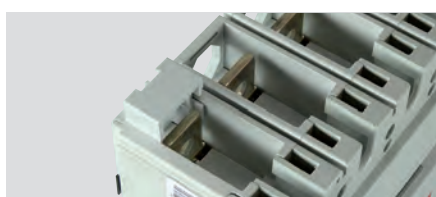

- After installing all the rear terminals (6 or 8), put the terminal cover, a sealing of it is possible.



- Turn the adjustable terminal to the desired angle and then tighten (25 N.m) the rear terminal using the product screw (8 mm Allen key).

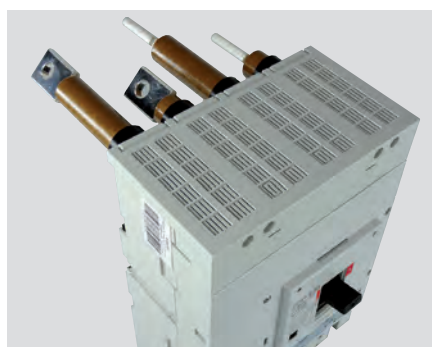

- Here are the different dimensions of the rear terminals as well as the permissible lengths and diameters of the connection ranges :

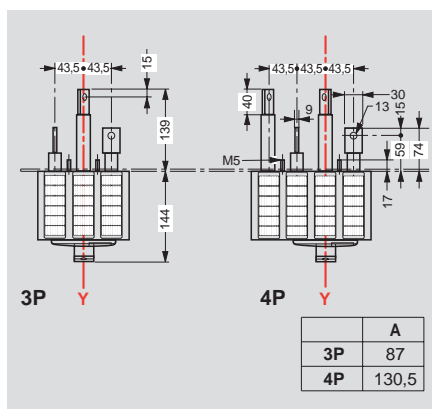

13 ADAPTOR FOR LUG CAT.NO 0 262 46

This accessory can be connected on one side to a cage terminal and on the other on lugs. It is not possible to install a terminal cover.

The material of these adaptors is silver coated copper.

Composition of the Cat.no :

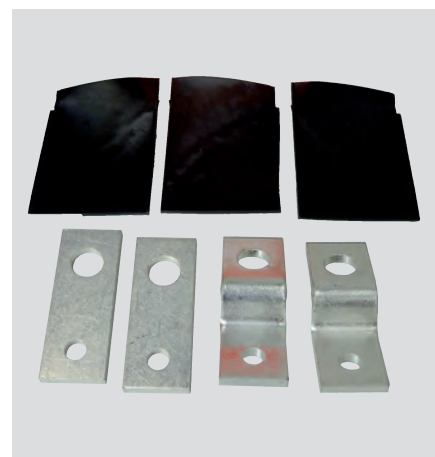

14 EXTENDED FRONT TERMINALS CAT.NO 0 262 47

This accessory facilitates the connection of cables with lug (2 Maxi).

The material of these extended front terminals is silver coated copper.

Composition of the Cat.no :

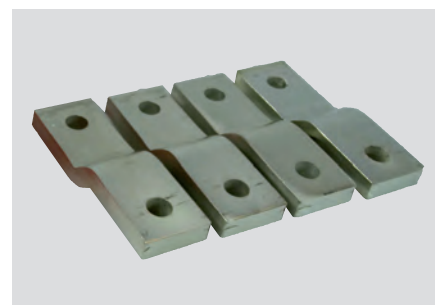

15 SET OF 3 (CAT.NO 0 262 48) OR 4 (CAT.NO 0 262 49) INCOMING OR OUTGOING SPREADERS

This accessory is used to facilitate cable connection.
Composition of the Cat.no 0 262 48 :

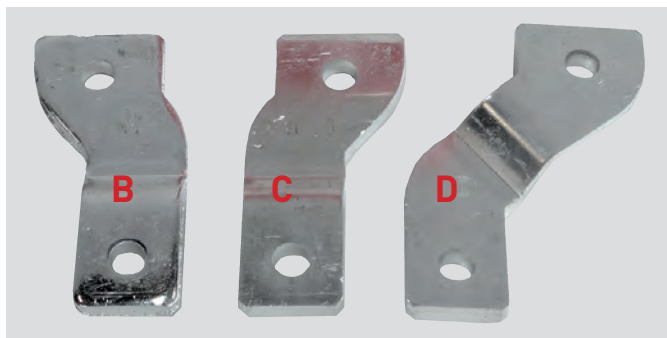

i In the case of use of spreaders, it is possible to use insulated shields but no terminal cover.

Dimensions of the part A (not shown on the picture, corresponding to the neutral for a 4P product) :

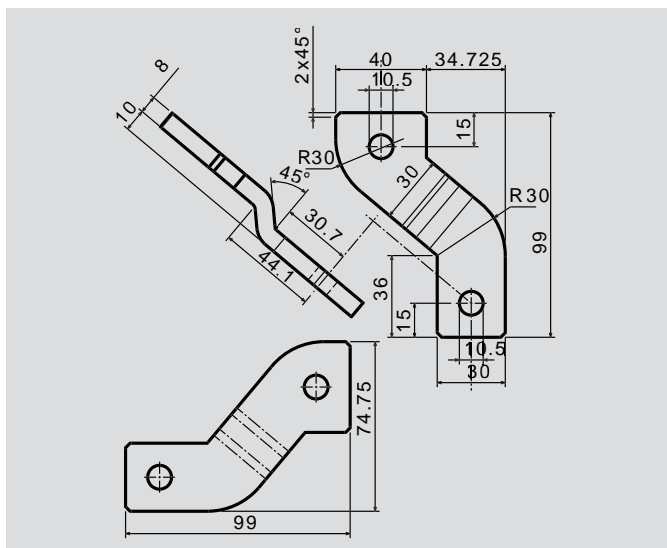

Dimensions of the part B (L1) :

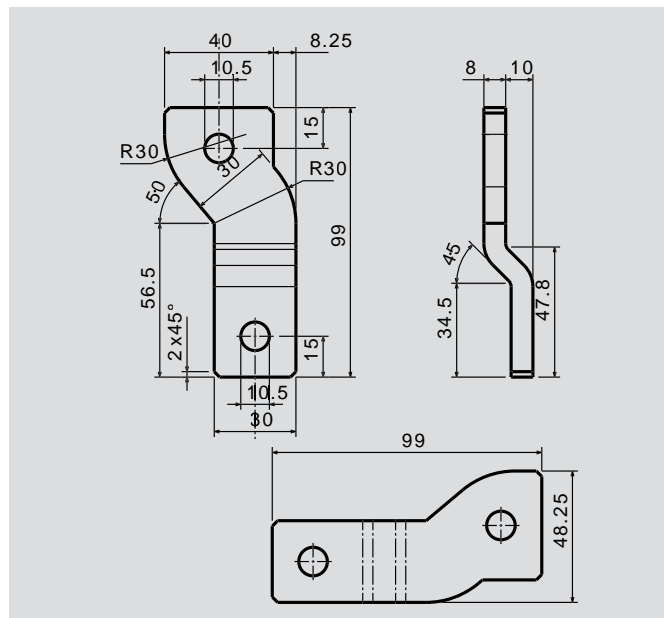

Dimensions of the part C (L2) :

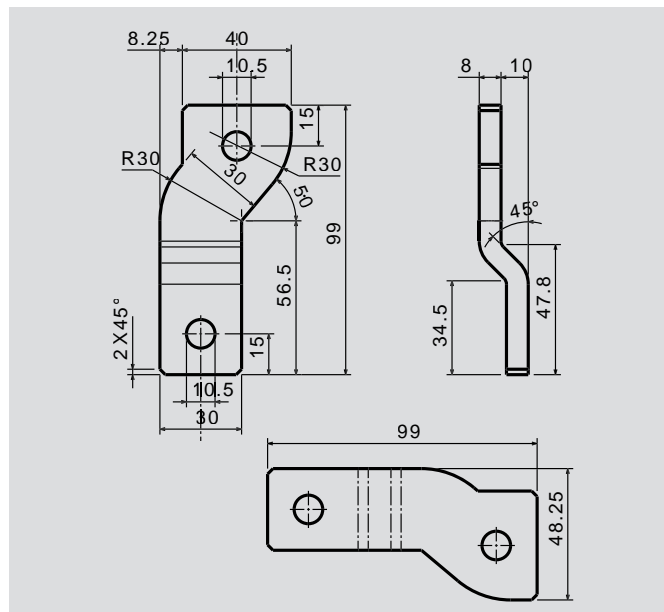

Dimensions of the part D (L3) :

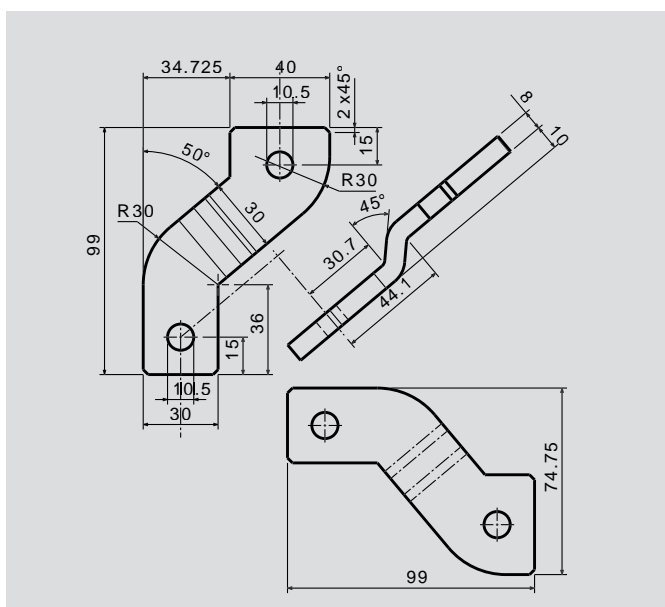

16 SET OF 3 INSULATED SHIELDS CAT.NO 0 262 30

Their role is to avoid the propagation of an electric arc in the event of a short circuit.

Composition of the Cat.no :



17 SEALABLE TERMINAL SHIELDS CAT.NO 0 262 44 (3P) OR 0 262 45 (4P) → UPSTREAM AND DOWNSTREAM

Pre-cut cuts are present. They allow to adapt the passage of the cables in the terminal cover.

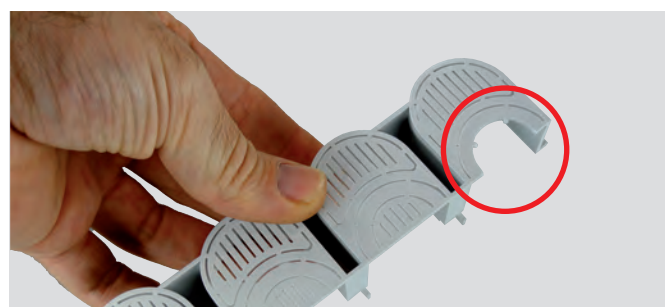
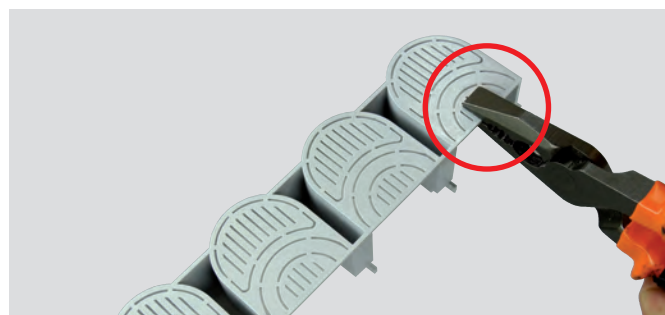

Here is the setting up of a cable with the 2 pre-cut parts on both sides as well as the mounted terminal cover :



A sealing is also possible and supplied with the Cat.no (X4).



18 PADLOCK FOR LOCKING IN OPEN POSITION (CAT.NO 0 262 40)

Composition of the Cat.no :

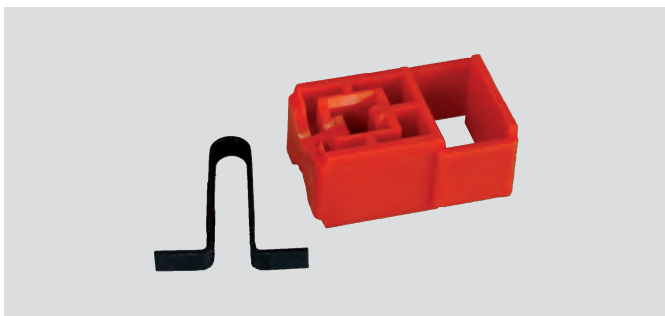

In order to set up, the handle of the MCCB on position "0" and then insert the part in the form of Omega (Ω form part) in the intended housing :



Place the red plastic part in position and insert a padlock with a diameter of 4 mm to 6 mm max. :



Padlock 6 mm diameter Cat.no 0 227 97.

19 IP20 TERMINAL COVER - 3P CAT.NO 4 222 34 (3P) OR 4 222 35 (4P)

The clipwise is on the front side of the screw holes.

Composition of the Cat.no 4 222 35 :



20 PLATE FOR DRAW-OUT VERSION CAT.NO 4 222 36

This plate is required when you want to install the contacts Cat. no 0 263 99 or 0 098 19 on the back of a DPX³. It comes with 4 fixing screws. Here is a picture illustrating this plate once set up behind the debro-lift mechanism:

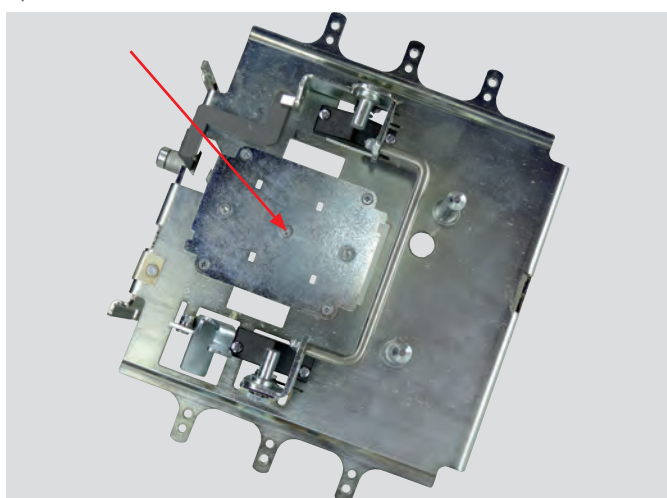

For mounting details, see paragraph 2 in the section "mechanical accessories" as well as the instructions sheet for the debro-lift Cat.no 4 222 31 or 4 222 32 or 4 222 33.

21 RETROFIT KIT FOR DPX TO DPX³ CAT.NO 4 222 37

This kit is required when you have a DPX³ 630 and you want to install it in an plug-in version. This kit is also required when replacing a DPX 630 with a DPX³ 630 in plugged-in, draw-out or motor drive version.



The installation of the screws, the metal tab, the shaft and the positioning of the inserts are shown on the instruction sheets. A further installation of the metal tab and the shaft is also available in paragraph 6 "electrical accessories" (motor drive).

DPX³ 1600

Product description

1 FRONT FACE OF THE CIRCUIT BREAKER



Example of setting a thermal magnetic circuit breaker :

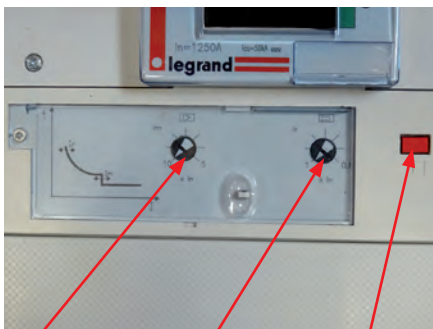

Magnetic protection adjustment

Thermal protection adjustment

Test button



The settings are sealable using Cat.no 4 210 95. (1 also comes with each circuit breaker).

2 FRONT FACE OF THE SWITCH

Like all DPX³ trip-free switches, the switches have a gray color handle.



3 POSITION OF THE HANDLE



Closed (ON).



Tripped.

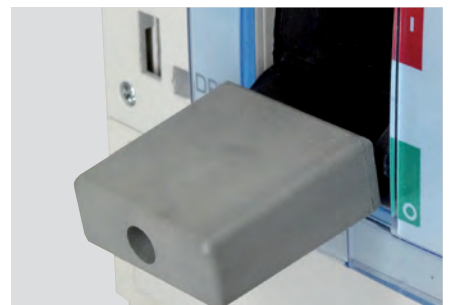

Open (OFF).

4 SETTINGS

	Overloads thermal protection		Short-circuits magnetic protection		Earth fault protection		Adjustment of the neutral
Thermal magnetic	I _r adjustable 0.8-1 x I _n	-	I _i adjustable 5-10 x I _n	-	-	-	-
Electronic S1	I _r adjustable 0.4 à 1 x I _n	Permanent = 5s (MEM ON)	I _{sd} adjustable 1.5 - 2 - 2.5 - 3 - 4 - 5 - 6 - 7 - 8 - 10 x I _r	Permanent = 100ms	-	-	OFF - 0.5 - 1 x I _n
Electronic S2	I _r adjustable (1A by 1A) 0.4 to 1 x I _n	t _r adjustable (MEM ON or MEM OFF) 3 - 5 - 10 - 15 - 20 - 25 - 30 s	I _{sd} adjustable 1.5 - 2 - 2.5 - 3 - 4 - 5 - 6 - 7 - 8 - 9 - 10 x I _r	t _{sd} adjustable (I ² t=k or t = k) 0 - 0.1 - 0.2 - 0.3 - 0.4 - 0.5 s	-	-	OFF - 0.5 - 1 - 1.5 - 2 x I _r
Electronic Sg	I _r adjustable (1A by 1A) 0.4 to 1 x I _n	t _r adjustable (MEM ON or MEM OFF) 3 - 5 - 10 - 15 - 20 - 25 - 30 s	I _{sd} adjustable 1.5 - 2 - 2.5 - 3 - 4 - 5 - 6 - 7 - 8 - 9 - 10 x I _r	t _{sd} adjustable (I ² t=k or t = k) 0 or 0.1 or 0.2 - 0.3 - 0.4 - 0.5 s	I _g adjustable 0.2 - 0.3 - 0.4 - 0.5 - 0.6 - 0.7 - 0.8 - 0.9 - 1 x I _n	t _g adjustable 0 or 0.1 or 0.2 - 0.5 - 1 s	OFF - 0.5 - 1 - 1.5 - 2 x I _r
Magnetic	-	-	I _{sd} adjustable 5-10 x I _n	-	-	-	-

■ Thermal magnetic settings :

For thermal magnetic circuit breakers, only the settings corresponding to the marking positions have been tested. The other setting values are given as an indication.

Electronic card consumptions :

- Electronic DPX³: 50 mA
- Electronic DPX³ with measurement: 62.5 mA
- DPX³ electronic residual current protection: 50 mA
- DPX³ electronic residual current protection with measurement: 62.5 mA

DPX³ 1600 MT

Thermal : Ir			Current (A)				
Catch	Ir multiplying factor	Mark	500	630	800	1000	1250
1	0.80	0.8	400	504	640	800	1000
2	0.83		415	523	664	830	1038
3	0.87		435	548	696	870	1088
4	0.90		450	567	720	900	1125
5	0.93		465	586	744	930	1163
6	0.96		480	605	768	960	1200
7	1.00	1	500	630	800	1000	1250

Magnetic ≤ 1000 A			Current (A)				Magnetic 1250 A			
Catch	In multiplying factor	Mark	500	630	800	1000	Catch	In multiplying factor	Mark	1250
1	5.0	5	2500	3150	4000	5000	1	5.0	5	6250
2	5.8		2900	3654	4640	5800	2	5.8		7250
3	6.7		3350	4221	5360	6700	3	6.7		8375
4	7.5		3750	4725	6000	7500	4	7.5		9375
5	8.3		4150	5229	6640	8300	5	8.3		10375
6	9.2		4600	5796	7360	9200	6	9.2		11500
7	10.0	10	5000	6300	8000	10000	7	10.0	10	12500

Values li at +/-20% in amps.

DPX³ 1600 Electronic S1

Thermal : Ir			Current (A)					
Catch	Ir multiplying factor	Mark	500	630	800	1000	1250	1600
1	0.40	0.40*	200*	252*	320*	400 *	500*	640*
2	0.45	0.45*	225*	284*	360*	450 *	563*	720*
3	0.50	0.50*	250*	315*	400*	500 *	625*	800*
4	0.55	0.55*	275*	347*	440*	550 *	688*	880*
5	0.60	0.60*	300*	378*	480*	600 *	750*	960*
6	0.65	0.65*	325*	410*	520*	650 *	813*	1040*
7	0.70	0.70*	350*	441*	560*	700 *	875*	1120*
8	0.75	0.75*	375*	473*	600*	750 *	938*	1200*
9	0.85	0.85*	425*	536*	680*	850 *	1063*	1360*
10	0.95	0.95*	475*	599*	760*	950 *	1188*	1520*
	1.00		500	630	800	1000	1250	1600

* adjustable at 0 - 0.005 - 0.01 - 0.015 - 0.02 - 0.025 - 0.03 - 0.035 - 0.04 - 0.05

Magnetic : Isd			Current (A)					
Catch	Ir multiplying factor	Mark	500	630	800	1000	1250	1600
1	1.5	1.5	300 to 750	378 to 945	480 to 1200	600 to 1500	750 to 1875	960 to 2400
2	2.0	2.0	400 to 1000	504 to 1260	640 to 1600	800 to 2000	1000 to 2500	1280 to 3200
3	2.5	2.5	500 to 1250	630 to 1575	800 to 2000	1000 to 2500	1250 to 3125	1600 to 4000
4	3.0	3.0	600 to 1500	756 to 1890	960 to 2400	1200 to 3000	1500 to 3750	1920 to 4800
5	4.0	4.0	800 to 2000	1008 to 2520	1280 to 3200	1600 to 4000	2000 to 5000	2560 to 6400
6	5.0	5.0	1000 to 2500	1260 to 3150	1600 to 4000	2000 to 5000	2500 to 6250	3200 to 8000
7	6.0	6.0	1200 to 3000	1512 to 3780	1920 to 4800	2400 to 6000	3000 to 7500	3840 to 9600
8	7.0	7.0	1400 to 3500	1764 to 4410	2240 to 5600	2800 to 7000	3500 to 8750	4480 to 11200
9	8.0	8.0	1600 to 4000	2016 to 5040	2560 to 6400	3200 to 8000	4000 to 10000	5120 to 12800
10	10.0	10.0	2000 to 5000	2520 to 6300	3200 to 8000	4000 to 10000	5000 to 12500	6400 to 16000

Ir and Isd values at +/-10% in amps.

For S1, the tr is fixed to 5 seconds. Tsd = 100ms

DPX³ 1600 Electronic S2

Thermal : I _r			Current (A)					
LCD	I _r multiplying factor	Mark	500	630	800	1000	1250	1600
	0.4 to 1	1A by 1A	200 to 500	252 to 630	320 to 800	400 to 1000	500 to 1520	640 to 1600

Magnetic : I _{sd}			Current (A)					
LCD	I _r multiplying factor	Mark	500	630	800	1000	1250	1600
	1.5	1.5	300 to 750	378 to 945	480 to 1200	600 to 1500	750 to 1875	960 to 2400
	2.0		375 to 1000	504 to 1260	620 to 1600	800 to 2000	1000 to 2500	1280 to 3200
	2.5		500 to 1250	630 to 1575	800 to 2000	1000 to 2500	1250 to 3125	1600 to 4000
	3.0		600 to 1500	756 to 1890	960 to 2400	1200 to 3000	1500 to 3750	1920 to 4800
	4.0		800 to 2000	1008 to 2520	1280 to 3200	1600 to 4000	2000 to 5000	2560 to 6400
	5.0		1000 to 2500	1260 to 3150	1600 to 4000	2000 to 5000	2500 to 6250	3200 to 8000
	6.0		1200 to 3000	1512 to 3780	1920 to 4800	2400 to 6000	3000 to 7500	3840 to 9600
	8.0		1600 to 4000	2016 to 5040	2560 to 6400	3200 to 8000	4000 to 10000	5120 to 12800
	9.0		1800 to 4500	2268 to 5670	2880 to 7200	3600 to 9000	4500 to 11250	5760 to 14400
	10.0	10	2000 to 5000	2520 to 6300	3200 to 8000	4000 to 10000	5000 to 12500	6400 to 16000

tsd = 0 – 100 – 200 – 300 – 400 – 500 ms (t = K)
 tsd = 0 – 100 – 200 – 300 – 400 – 500 ms (I²t = k) (**)
 (**) @ 12 I_r
 I_{sd} values at +/- 10% amps.

DPX³ 1600 Electronic Sg

Thermal : I _r			Current (A)					
LCD	I _r multiplying factor	Mark	500	630	800	1000	1250	1600
	0.4 to 1	1A by 1A	200 to 500	252 to 630	320 to 800	400 to 1000	500 to 1250	640 to 1600

Magnetic : I _{sd}			Current (A)					
LCD	I _r multiplying factor	Mark	500	630	800	1000	1250	1600
	1.5	1.5	300 to 750	378 to 945	480 to 1200	600 to 1500	750 to 1875	960 to 2400
	2.0	2	375 to 1000	504 to 1260	620 to 1600	800 to 2000	1000 to 2500	1280 to 3200
	2.5	2.5	500 to 1250	630 to 1575	800 to 2000	1000 to 2500	1250 to 3125	1600 to 4000
	3.0	3	600 to 1500	756 to 1890	960 to 2400	1200 to 3000	1500 to 3750	1920 to 4800
	4.0	4	800 to 2000	1008 to 2520	1280 to 3200	1600 to 4000	2000 to 5000	2560 to 6400
	5.0	5	1000 to 2500	1260 to 3150	1600 to 4000	2000 to 5000	2500 to 6250	3200 to 8000
	6.0	6	1200 to 3000	1512 to 3780	1920 to 4800	2400 to 6000	3000 to 7500	3840 to 9600
	8.0	8	1600 to 4000	2016 to 5040	2560 to 6400	3200 to 8000	4000 to 10000	5120 to 12800
	9.0	9	1800 to 4500	2268 to 5670	2880 to 7200	3600 to 9000	4500 to 11250	5760 to 14400
	10.0	10	2000 to 5000	2520 to 6300	3200 to 8000	4000 to 10000	5000 to 12500	6400 to 16000

I _g earth fault protection			Current (A)					
LCD	I _r multiplying factor	Mark	500	630	800	1000	1250	1600
	0.2	0.2	100	126	160	200	250	320
	0.3	0.3	150	189	240	300	375	480
	0.4	0.4	200	252	320	400	500	640
	0.5	0.5	250	315	400	500	625	800
	0.6	0.6	300	378	480	600	750	960
	0.7	0.7	350	441	560	700	875	1120
	0.8	0.8	400	504	640	800	1000	1280
	0.9	0.9	450	567	720	900	1125	1440
	1.0	1	500	630	800	1000	1250	1600
	OFF	OFF	S2	S2	S2	S2	S2	S2

tsd = 0 - 100 - 200 - 300 - 400 - 500 ms (t = K)

tsd = 0 - 100 - 200 - 300 - 400 - 500 ms (I²t = k) (**)

(**) @ 12 I_r

tg : 0.1 - 0.2 - 0.3 - 0.4 - 0.5 - 1 s

I_{sd} values at +/- 10% amps.

DPX³ 1600 electrical accessories

■ **Auxiliary contact/ fault signalling contact**

- 4 210 11

■ **Shunt releases**

- 4 222 39 24V AC/DC
 - 4 222 40 48V AC/DC
 - 4 222 41 110V AC/DC
 - 4 222 42 230V AC/DC
 - 4 222 43 400V AC/DC

■ **Undervoltage releases**

- 4 222 44 24V DC
 - 4 222 45 24V AC
 - 4 222 46 48V DC
 - 4 222 47 110V AC
 - 4 222 48 230V AC
 - 4 222 49 400V AC
 (power supply included)

■ **Time-lag modules**

- 0 261 90 230V AC
 - 0 261 91 400V AC
 - 4 226 23 Time-lag modules release

■ **Motor-driven handle (front installation)**

- 0 261 19 24V AC/DC $I_n \leq 1600A$
 - 0 261 23 230V AC/DC $I_n \leq 1250A$
 - 0 261 24 24V AC/DC $I_n \leq 1250A$
 - 0 261 25 48V AC/DC $I_n \leq 1250A$
 - 0 261 26 110V AC/DC $I_n \leq 1250A$
 - 0 26127 230V AC/DC $I_n \leq 1600A$
 - 0 26128 48C AC/DC $I_n \leq 1600A$
 - 0 261 29 110V AC/DC $I_n \leq 1600A$
 - 0 261 50 24V AC/DC
 (factory mounting : motor + DPX³/DPX³ - I)
 - 0 261 51 48V AC/DC
 (factory mounting : motor + DPX³/DPX³ - I)
 - 0 261 54 230V AC
 (factory mounting : motor + DPX³/DPX³ - I)

■ **Locking accessory for motor-driven handle**

- 0 261 58 star key
 - 0 261 59 flat key

■ **Set of connectors - 8 contacts (rear installation)**

- 0 263 99 debro-lift version

■ **Set of connectors - 6 contacts (rear installation)**

- 0 098 19 debro-lift version

■ **Set of connectors - 24 contacts (side installation)**

- 4 222 29

■ **Signalling contact**

- 0 265 74 draw-in/draw-out

■ **Set of contacts (12) (side installation)**

- 4 222 30 for draw-out version

■ **External neutral**

- 4 225 92

■ **Plate for signalling contact**

- 4 225 95 draw-out version

1 AUXILIARY CONTACT/FAULT SIGNALLING (OC/CTR CAT.NO 4 210 11)



All DPX³ circuit breakers and switches can be equipped with electrical auxiliaries to ensure control functions. The auxiliary contact Cat.no 4 210 11 is common to the entire DPX³ range.

Depending on its insertion position in the DPX³ case, the contact acts either as an auxiliary contact or as a fault signalling contact.

The auxiliary contact OC allows the signalling of the position of the main contacts of the circuit breaker or the switch (open or closed). It is neither anticipated nor delayed.

The fault signalling contact (CTR) indicates that the circuit breaker has opened on default, per action of a trigger, by a draw-out operation or by mechanical action on the red "test" button.

These contacts are of the changeover type (NO-NC) with dry contact (potential free).

Electrical characteristics (OC & CTR)

VOLTAGE	CURRENT (A)	
	RESISTIVE LOAD	INDUCTIVE LOAD
24 Vdc	10	5
48 Vdc	1,3	0,7
110 Vdc	0,4	0,3
230 Vdc	0,3	0,2
110 Vac	10	4
230 Vac	6	2

OC contact :

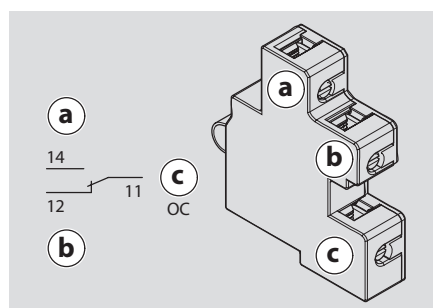

OC contact position :

	OC	12 - 11	14 - 11
OFF			
Triggered			
ON			

CTR contact :

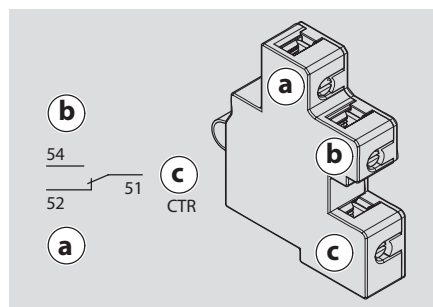

CTR contact position :

	CTR	52 - 51	54 - 51
OFF			
Triggered			
ON			

Setting up OC/CTR contacts:

- Press the red "test" button to trigger the product and have the handle in the intermediate position (triggered).

- Remove the 4 screws from the cover



- Remove the transparent cover by removing the screw.



- Insert the OC contacts

It is possible to install a maximum of 3 OC contacts.



Cable exit can be from the back, the right or left side of the MCCB :

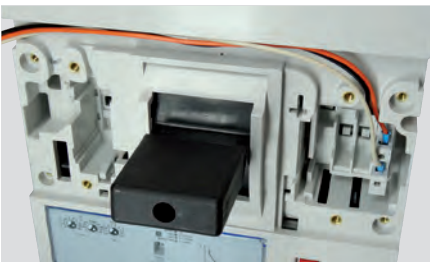

For the lateral output, the pre-cut of the front cover must be broken in order to clear the passage :

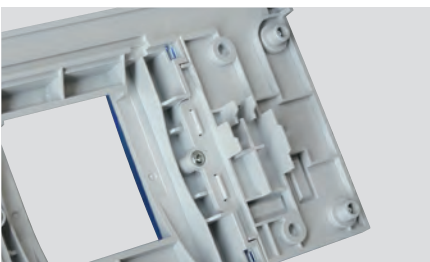

- Set up the CTR contact

 Its location is dedicated, only one location is possible.



Cable exit can be from the back or right side :

 The CTR contact is 180 ° in the housing in relation to an OC contact: the wires go down (see pictures below).



The permissible section of the cables extends from 0.35 mm² to 1.5 mm². In the case where several OC and CTR are present, the recommended section is 0.50 mm².

To replace the transparent cover, make sure that the 2 tabs (before setting the screw) are correctly placed on the bottom in their housing :

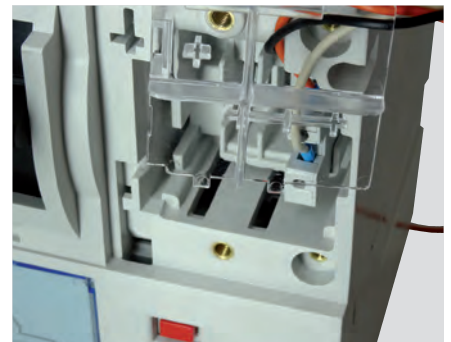

2 SHUNT RELEASES (EXAMPLE CAT.NO 4 222 42)



Shunt releases allow the instantaneous opening ($\leq 50\text{ms}$) of the device by the power of their coil: external contact control NO.

The contact incorporated into the shunt release shuts off the power supply during an opening control (e.g., emergency stop to snap), thus avoiding the heating problem. The permanent supply of the shunt release is possible, preventing DPX³ contacts to close.

Electrical characteristics

OPERATING VOLTAGE	AC : 24V/110V/ 230V/400V DC : 24V/48V
Operating range IEC 60947-2	70 à 110% Un
Response time	$\leq 50\text{ms}$
Inrush power	300VA/W
Request time	$>50\text{ms}$
Isolation voltage	2,5kV

■ Setting up :

A single location is provided for mounting regardless of the product of the DPX³ 1600 range.

These shunt releases are mounted on the left of the product (front view). Only one cable output is possible: side output.

3 UNDERVOLTAGE RELEASES (EXAMPLE CAT.NO 4 222 48)



Undervoltage releases allow the instantaneous opening ($\leq 50\text{ms}$) of the device by switching off the power supply ($< 85\%$ UN) of the coil: positive safety (e.g. emergency stop by external contact NF).

Undervoltage releases must be pre-energized before putting the associated DPX³ in the reset position (OFF) to reset the product.

Electrical characteristics

OPERATING VOLTAGE	AC : 24V/110V/ 230V/400V DC : 24V/48V
Operating range IEC 60947-2	85 to 110% Un
Response time	$< 50\text{ms}$
Holding power	1,6W/5VA

■ Setting up :

A single location is provided for mounting regardless of the product of the DPX³ 1600 range.

These undervoltage releases are mounted on the left of the product (front view).

Wiring and cable passage are identical to shunt releases.

4 800 ms TIME-LAG MODULES

- 0 261 90 : Voltage 230 VAC (2 terminal covers + 1 rail)
- 0 261 91 : Voltage 400 VAC (2 terminal covers + 1 rail)
- 4 226 23 : time-lag module release to join with Cat.no 0 261 90 or 0 261 91.

The wiring is done in parallel.

Example :

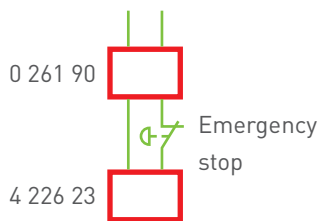

5 MOTOR DRIVE (FRONT INSTALLATION)

5.1. Principle

The DPX³ 1600 engine offers a significant advantage in all commercial building installations, allowing to close or open a remote switch or circuit breaker. If used as a transfer switch, its control is autonomous using the automatic transfer switch control units Cat.nos 4 226 80-4 226 82-4 226 83.

Two motor ranges are available for the DPX³ 1600, a standard range and a factory-configured range only.

Configured : the front panel has a controller to charge the spring, a spring status indicator "loaded-unloaded ", a multifunction selector (auto-man-lock), a close button, an opening button and a locking device.

Standard : the front panel has a controller for charging the spring, an operation

indicator, an operation selector, a multifunction selector (AUTO – MAN – lock), a closing button, an opening button and a device for lock.

Available in several voltages, either continuously or alternatively: 24 –48 VDC, 24 – 48 – 110 – 230 VAC. There are also two possibilities of electric controls, either by impulse or maintained.

In automatic mode, the motorized control allows to open, close or remotely rearman a DPX³.

In manual mode, electrical orders are not taken into account. The front handle allows you to manually load the spring, then close the associated device, to open the unit, simply press the red button.

In locked mode, it is not possible to control the motor electrically or manually. This mode is only possible when the DPX³ handle is in the "0" (open) position. It is possible to equip them with a lock by key (Cat.no 0 261 58/59) or padlock (3 Maxi. – diameter 6 mm max), thus prohibiting the closure of the DPX³ and the cancellation of all electrical orders.

For the safety of persons and equipment, when the motor cover is removed, a safety contact makes it ineffective to operate any electrical operation of the motor.

In the case of a transfer switch use, the switching time between the main line and the backup line (time between the opening of the main line and the closure of the backup line) is greater than or equal to 6s.

5.2. Diagrams

Configured motor

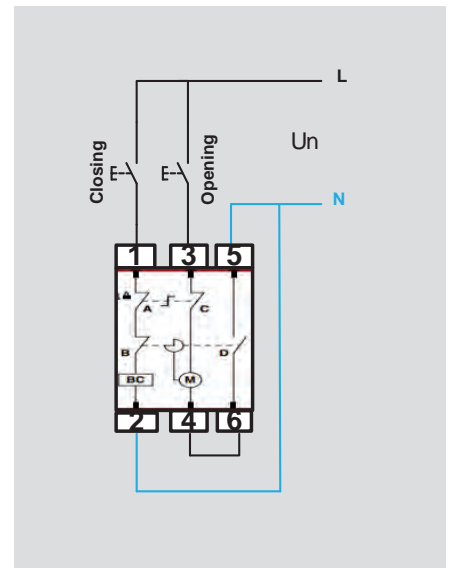

Standard motor

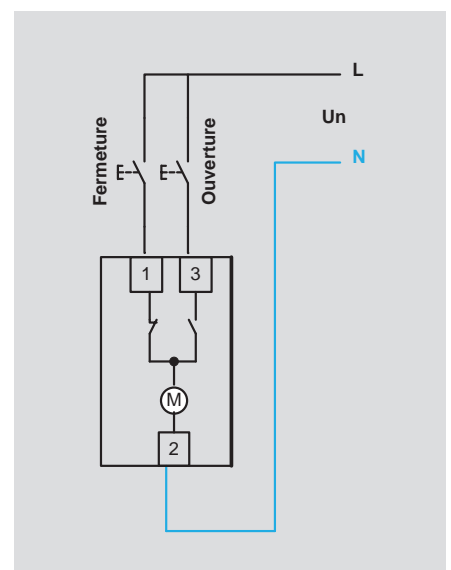

■ 5.3. Electrical characteristics

Configured motor:

Voltages - Un (V)	Power absorbed (VA/W)		Opening + rearming	Closing
	Inrush power	Steady state power		
24 Vdc	460	160	6s	≤ 100ms
48 Vdc	460	160	6s	≤ 100ms
24 Vac	460	160	6s	≤ 100ms
48 Vac	460	160	6s	≤ 100ms
110 Vac	460	160	6s	≤ 100ms
230 Vac	460	160	6s	≤ 100ms

Standard motor :

Voltages - Un (V)	Power absorbed (VA/W)		Closing	Opening
	Inrush power	Steady state power		
24 Vdc	460	110	4s	8s
48 Vdc	460	110	4s	8s
24 Vac	460	110	4s	8s
48 Vac	460	110	4s	8s
110 Vac	460	110	4s	8s
230 Vac	460	110	4s	8s

■ 5.4. Mounting (example Cat.no 0 261 27)

Composition of the Cat.no :



- Trigger the product by pressing the red test button, the handle is then in the intermediate position.
- Remove the 4 screws and pull out the circuit breaker cover.
- Remove the transparent plastic cover.

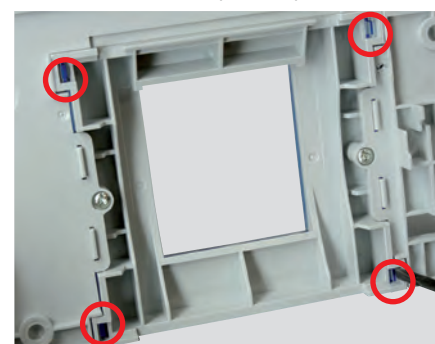

- Drill a 5 mm diameter hole and make the cuts for the information reports (button OFF – status report).

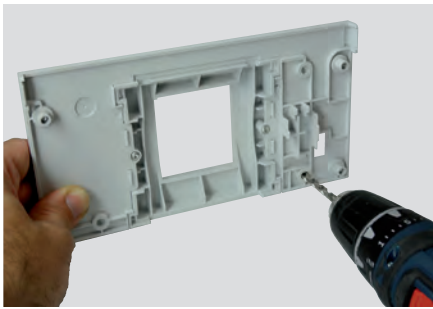

- Retrieve the blank label present in the product hole on the front, write on the label the reference of the associated device and then stick it to the front of the motor in the intended location.
- Put the frame back in place using the 4 screws.
- Assemble the tab and its axis on the support and fasten the whole to the product.

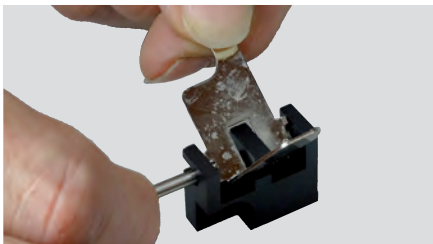

- Remove the protective screw from the handle.



- Set the motor drive slider to "MAN" and remove its cover.

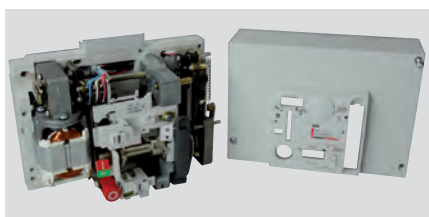

- Reload the spring of the motor drive with the handle.

- Insert the control into the product making sure that the handle is correctly positioned in the intended housing.

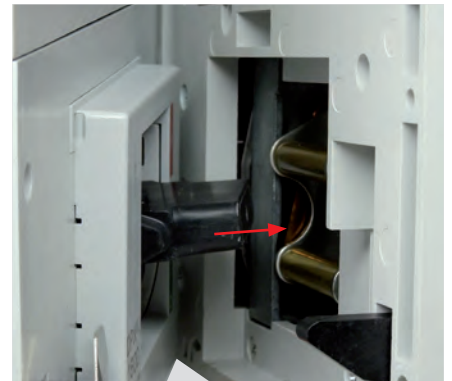

- Then fasten the motor with the 4 screws supplied (tightening torque of 2 N.m.), the screw at the bottom right is different from the other 3 :

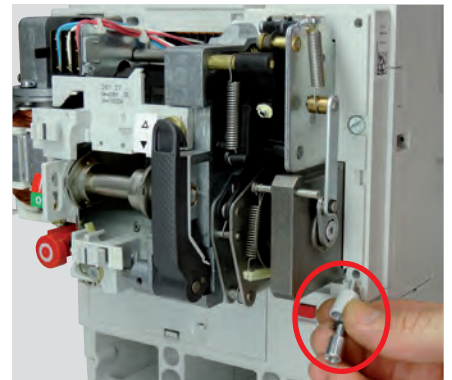

- Fasten the motor cover with the screws supplied (tightening torque of 1 N.m. Maxi).
- Perform some closing and opening operations in order to verify the proper functioning of the whole.

- It is possible to perform a lockout in the open position. To do this, press the button 0 of the motor drive, press and hold the cursor to "lock" to remove the tab :

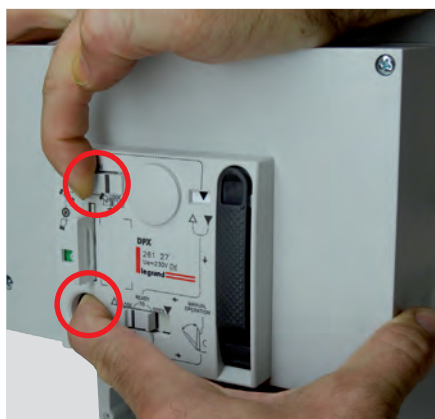

- We can then insert up to 3 padlocks with a diameter of 5 mm minimum to 6 mm maximum.

Example with a lock Cat.no 0 227 97 :



6 LOCKING ACCESSORY FOR MOTOR DRIVE (0 261 58/59)

Mounting is identical to the DPX³ 630 except the cam to be put in place at the rear (see page 30) :



DPX³ 630

DPX³ 1600

7 SET OF CONNECTORS - 8 CONTACTS (REAR INSTALLATION - 0 263 99)

Composition of the Cat.no :



Connection by Faston terminals. See Chapter 13 (mounting plate Cat.no 4 225 95, see pages 68 to 71).

8 SET OF CONNECTORS - 6 CONTACTS (REAR INSTALLATION - 0 098 19)

Composition of the Cat.no :



Terminal connection.

See Chapter 13 (mounting plate Cat.no 4 225 95, see pages 68 to 71).

9 SET OF CONNECTORS - 24 CONTACTS (SIDE INSTALLATION - 4 222 29)

This reference consists of 2 male/female connectors of 12 terminals each (24 terminals in total) allowing the connection of the accessories (OC - CTR - motor drive - coils).

It is only available in the international catalog.



The use of this product for a DPX³ 1600 will only be useful for the fixed version. In the draw-out version we will use the catalogue numbers :

- 0 263 99 or 0 098 19 for rear contacts
- 4 222 30 for lateral contacts

In a fixed installation, we will use the 2 supplied rails which are fixed either on the plate or on the uprights but close to the product so that it is easily disconnected.

Cabling and tracking will be identical to DPX³ 630 (see pages 31 and 32).

The different cable sections as well as the location recommendations of the wires are indicated on the installation instructions according to the accessories present.

10 **SIGNALLING CONTACT**
(CAT.NO 0 265 74)

It allows to send visual information about the state the debro-lift mechanism: connected or disconnected.

Composition of the Cat.no. :

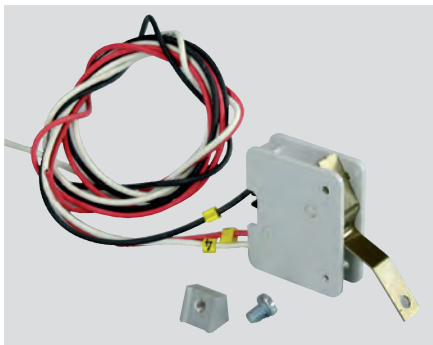

For mounting, we will not use the screw and the metal plate.



Pass the contact wires through the intended hole of the base and then insert the contact in the dedicated location respecting the direction :



11 **SET OF CONTACTS (12)**
(SIDE INSTALLATION - 4 222 30)

This reference is composed of 4 contacts of 3 terminals each. We can install up to 8 contacts per DPX³ (2 Cat.nos to order). These contacts are positioned on the side of the associated product. They can be installed on a product alone but also on 2 products mounted in source inversion.

Composition of the Cat.no :



In addition to the parts present in this catalogue number, others are necessary for a complete mounting. They are in the catalogue number of the debro-lift mechanism :

Necessary parts in the debro-lift mechanism (Cat.nos 4 225 93/94) :

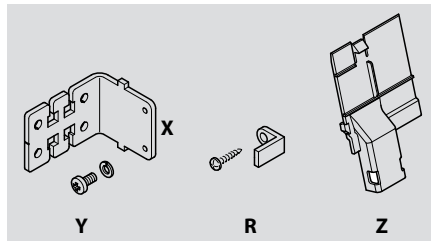

The mounting is detailed in the instructions of the base or of the debro-lift mechanism: common notice.

The different cable sections as well as the location recommendations of the wires are indicated on the instructions according to the accessories present.

12 **EXTERNAL NEUTRAL (4 225 92)**



The external neutral comes with a 3.5 m length cable equipped at its end with a connector. By its very simple and fast implementation, it allows to switch from a DPX³-3P to a DPX³-3P + N (neutral) without replacing the circuit breaker. It is compatible with all DPX³ 1600 – 3P – type S2 and SG trigger manufactured from date 15W50 (technical version revision 1).

It is mandatory to have the DPX³ in the open position (OFF) before plugging/unplugging the connector from the external neutral.

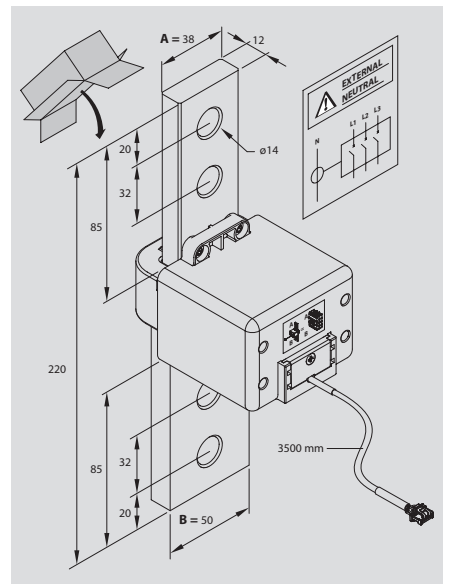

Compatibility with external neutral	Thermal magnetic trigger	Electronic trigger – type S1	Electronic trigger – type S2	Electronic trigger – type Sg	S2 and Sg trigger with measurement
DPX ³ 1600 – 3P – revision 0 – manufacturing prior to 15 W 50	X	X	X	X	X
DPX ³ 1600 – 3P – revision 1 – manufacturing after 15 W 50	X	X	X	X	X
DPX ³ 1600 – 4P all versions	X	X	X	X	X

■ Connection :

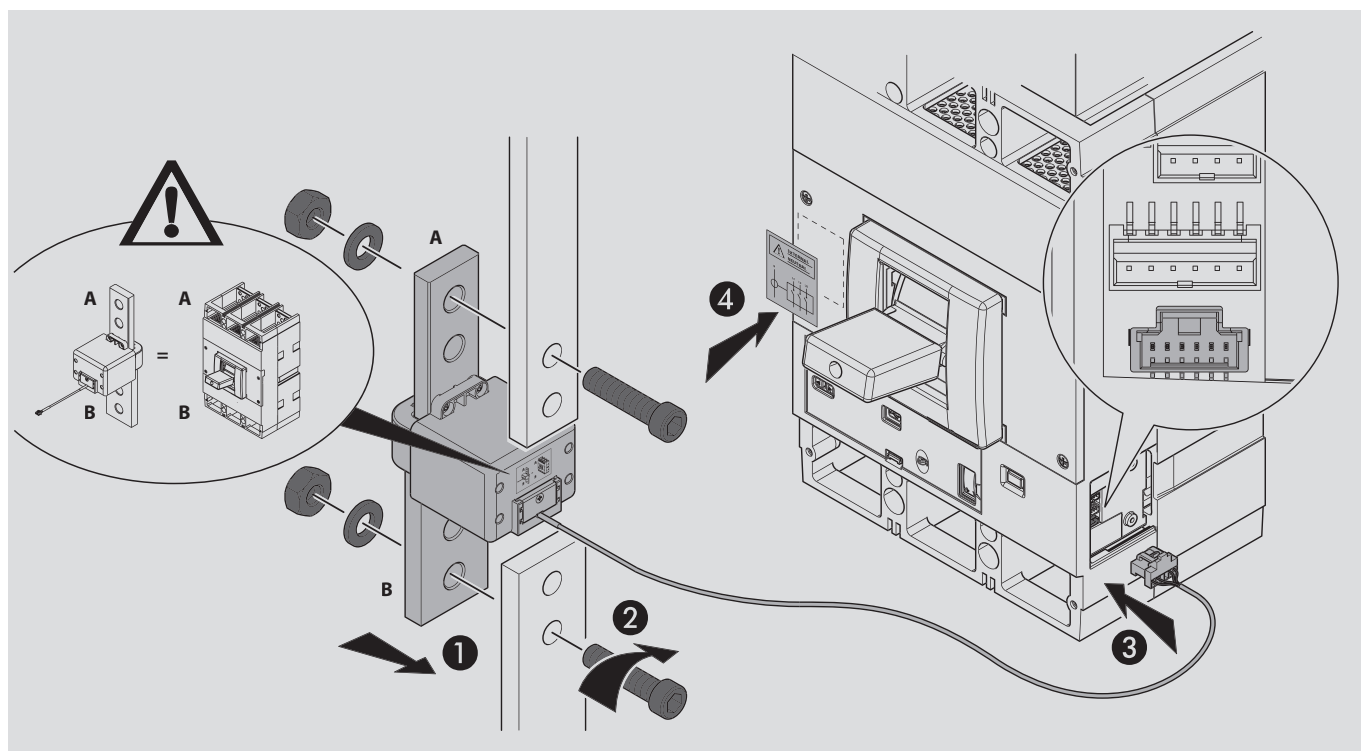

13 PLATE (CAT.NO 4 225 95)

This plate is necessary for the mounting of the signalling contacts Cat.no 0 263 99 or 0 098 19 in the case of a DPX³ in a draw-out version.

Composition of the Cat.no :

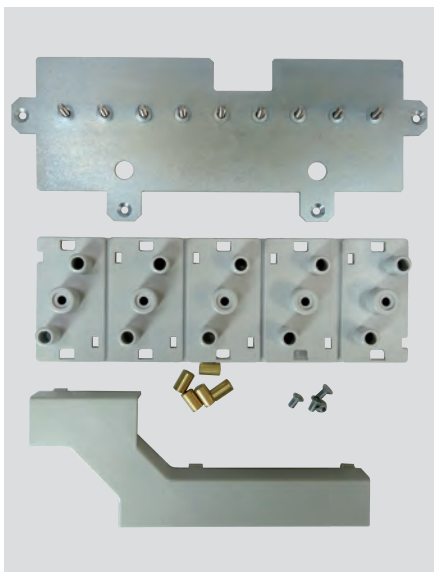

■ Mounting :

- In case of mounting on a DPX³ 3P, one of the 5 parts of the supplied plastic part must be broken :



- Fasten the metal plate using the 4 screws provided at the intended locations of the debro-lift mechanism (Philips footprint n° 1, tightening torque of 1 N.m.) :

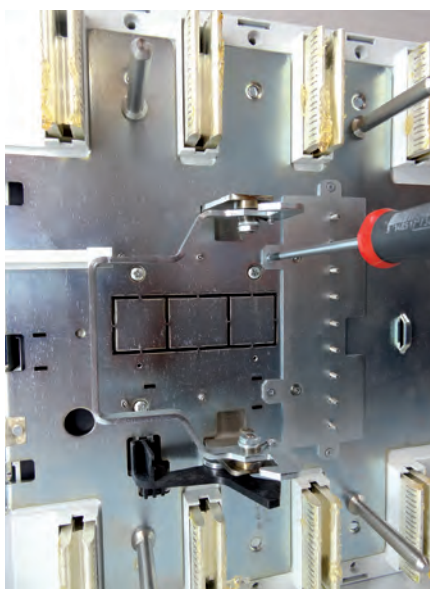
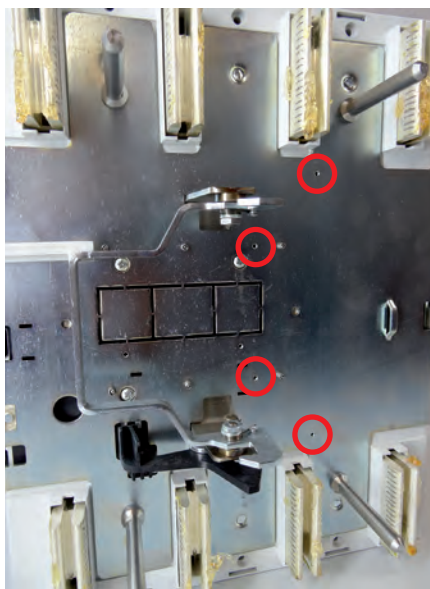

- Fix the plastic part on the metal plate using the 5 brass nuts supplied (screwing with 4 mm flat screwdriver, 1 N.m. tightening torque) :



With the set of connectors Cat.no 0 263 99 .

Composition of the Cat.no :



- Take the screw provided and insert it in the center of the male part in the hole provided and fasten the whole with a screwdriver Pozidriv No. 1 to the torque of 0.5 N.m.

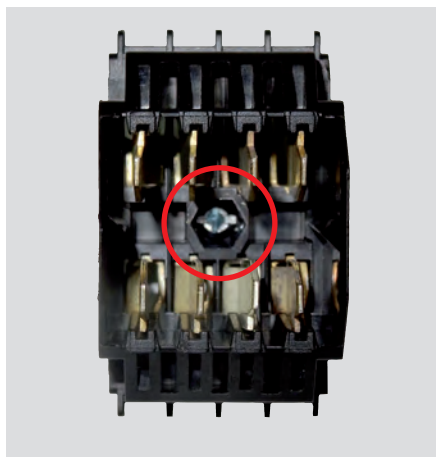

- Repeat these steps according to the number of connectors desired (5 maximum).

- For the female part of the connector, it is necessary to first remove the corresponding plastic part from the draw-out base :



- Clip the female part of the contact into the removable base (from the front of the base) :



- After having wired all the cables of the accessories, auxiliary contacts, etc..., set up the clip-on cable ducting supplied with the Cat.no 4 225 95 in order to conceal all the wires located to the right of the DPX³ (front view) :

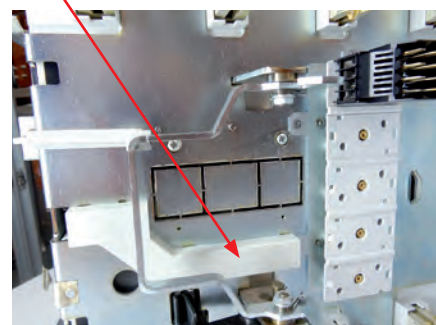

Location of wires (according to mounted accessories) detailed on page 20 of the installation instructions of the debró-lift mechanism Cat.no 4 225 93/94.

■ Set of connectors Cat.no 0 098 19

Composition of the Cat.no :

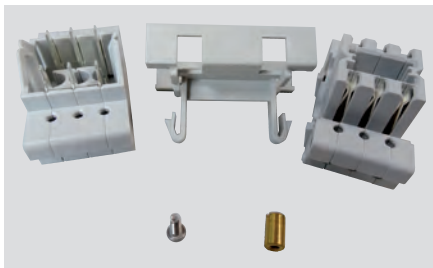

- Take the screw provided and insert it in the center of the male part in the hole provided and fasten the whole with a 4 mm flat screwdriver to the torque of 0.5 N.m. :



- Repeat these steps according to the number of connectors desired (5 maximum).

- For the female part of the connector, it is necessary to first remove the corresponding plastic part from the draw-out base :



- Clip the female part of the contact into the supplied plastic frame :

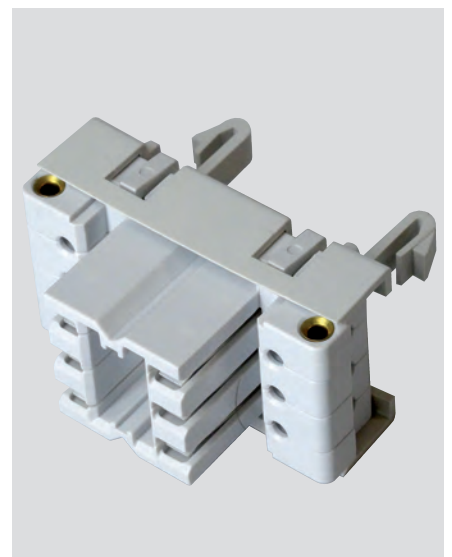
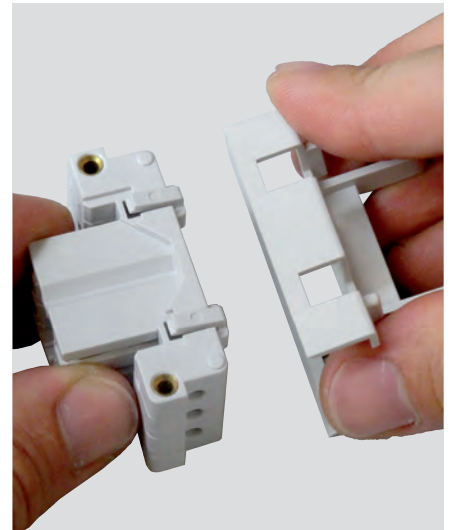

- Clip the whole into the base (from the front of the base) :

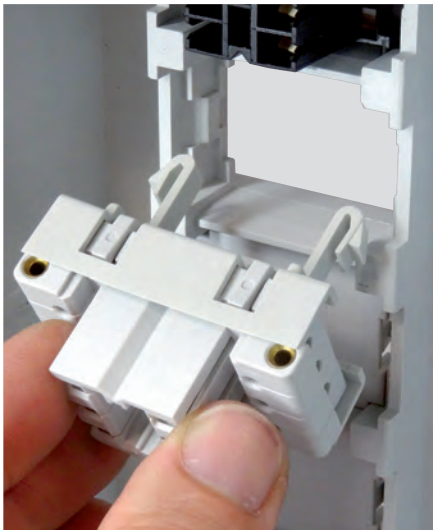

- After having wired all the cables (\varnothing 0.35 mm² mini, 1.5 mm² Maxi) of the accessories, auxiliary contacts, etc..., set up the clip-on cable ducting supplied with the Cat.no 4 225 95 in order to conceal all the wires located to the right of the DPX³ :

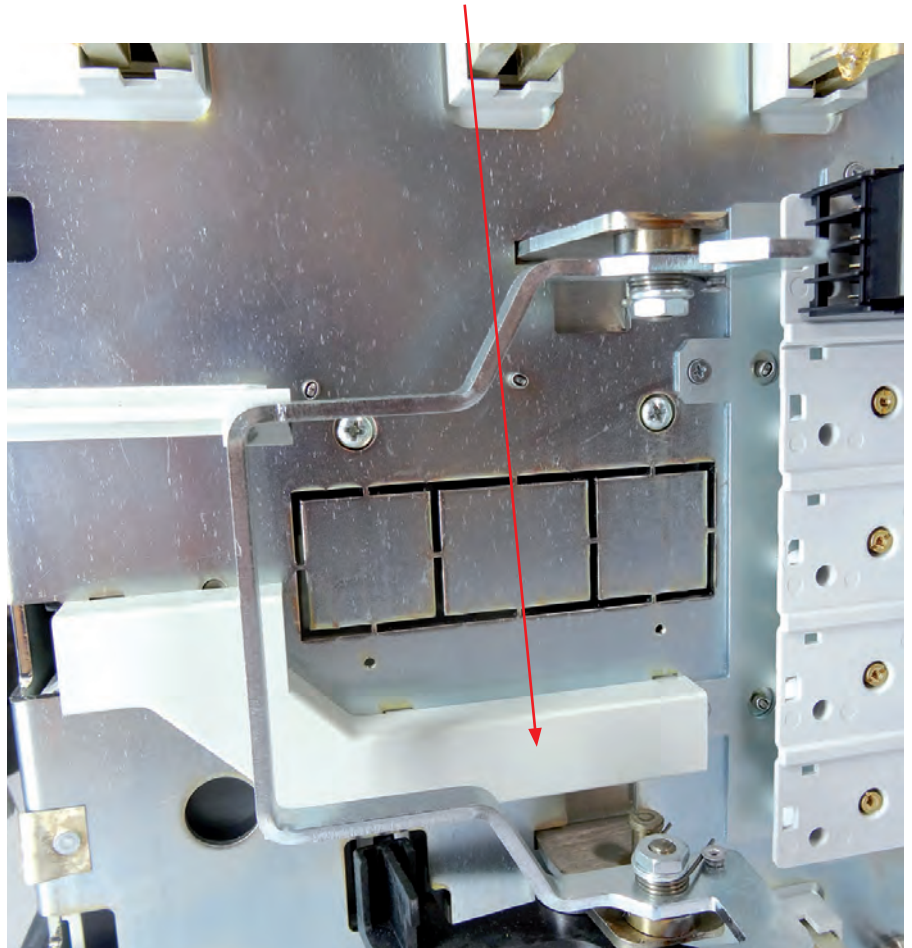

Location of wires (according to mounted accessories) detailed on page 21 of the manual of the debro-lift mechanism Cat.no 4 225 93/94.

DPX³ 1600 mechanical accessories

■ Terminals DPX³ 1600 draw-out version

- 4 225 86 front terminals 3P
- 4 225 87 front terminals 4P
- 4 225 88 rear terminals 3P
- 4 225 89 rear terminals 4P

■ Debro-lift mechanism

- 4 225 93 DPX³ 3P
- 4 225 94 DPX³ 4P

■ Drawing-out insulated handle for DPX 250 to 1600 debro-lift mechanism

- 0 265 75

■ Key lock for Debro-lift mechanism

- 0 265 76 flat key
- 0 263 48 star key

■ Rotary handle direct on DPX

- 0 262 61 standard (black)

■ Key-lock in draw-out position for motorised DPX³ or with rotary handle

- 0 265 79 star key
- 0 265 80 flat key

■ Rotary handle - vari-depth IP55

- 0 262 83 standard (black)
- 0 262 84 emergency (red/yellow)

■ Key-lock for rotary handle – vari-depth

- 0 262 92 Eurolock key
- 0 262 93 star key
- 0 262 94 flat key
- 4 228 04 flat key
- 4 228 05 flat key

■ Eurolock for rotary handle

- 0 262 25

■ Cage terminal (x1)

- 0 262 69 rigid cable 2x240 mm² / 2x185 mm² flexible
- 0 262 70 4x240² rigid cable 4x240 mm² / 4x185 mm² flexible

■ Extended front terminals

- 0 262 67 up to 1250A
- 0 262 68 1600A

■ Spreaders - rear terminals incoming/outgoing

- 0 262 73 3P
- 0 262 74 4P

■ Insulated shields (x3)

- 0 262 66

■ Sealable terminal shields

- 0 262 64 3P
- 0 262 65 4P

■ Set of 2 terminal covers - IP20

- 4 225 90 pour 3P
- 4 225 91 pour 4P

■ Padlock for locking in "open" position

- 0 262 60

■ Set of rear terminals (6) - incoming or outgoing

- 0 263 80 short 3P
- 0 263 81 long 3P
- 0 263 82 short 4P
- 0 263 83 long 4P

1 DPX³ BASE - DRAW-OUT VERSION

This product is required in the case of mounting the DPX³ in a draw-out version. It is fixed on the plate; the inversion of sources is possible. It can be installed in vertical or horizontal position, front or rear terminals, 3 poles or 4 poles.

■ Example of a base – front terminals 3P

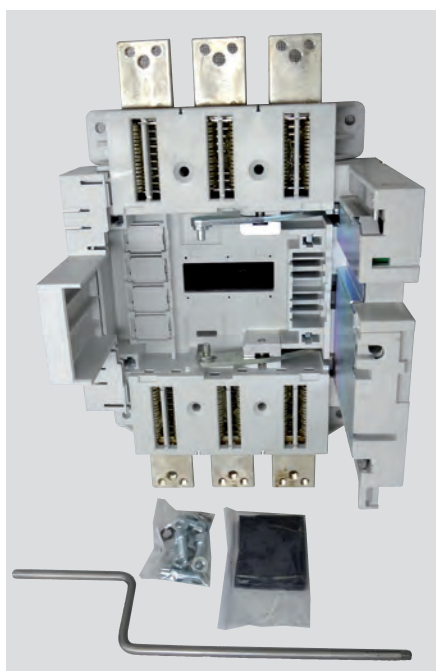

2 DEBRO-LIFT CAT.NO 4 225 93 (3P) /4 225 94 (4P)

The Debro-lift mechanism allows the operation of drawing-in / drawing-out without removing the faceplate and holding the circuit breaker or switch in its base.

A DPX³ is a DPX³ with a debro-lift mechanism + a base.

Composition of the Cat.no 4 225 94 :



View of all the parts included in the Cat.no :

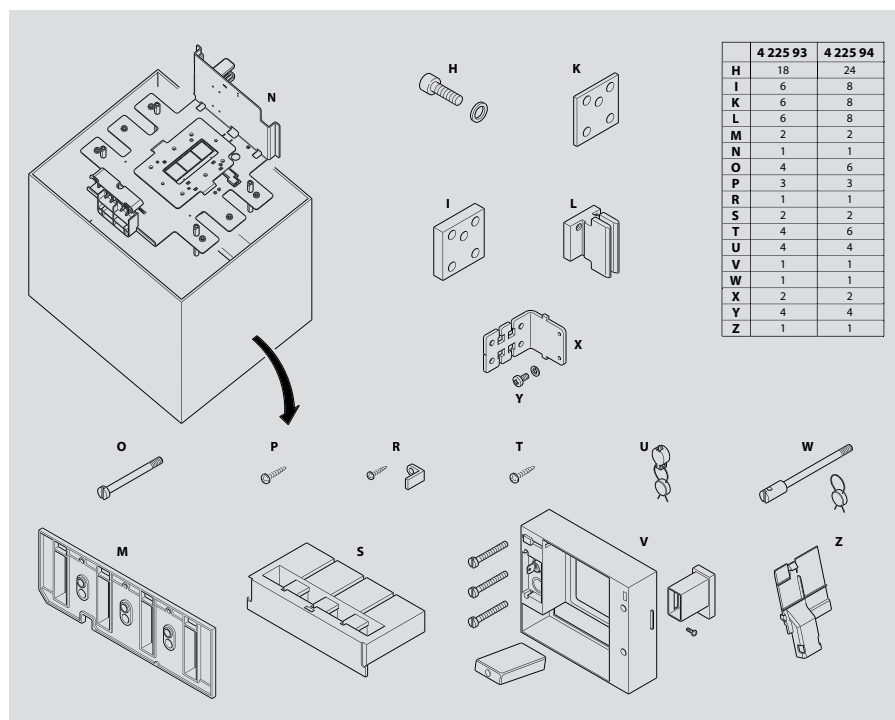

- It is necessary to equip the product with the rear connections supplied with the debro-lift mechanism (Mark L). We will use the 2 shims (K and I markers) for one in < 1000A and one shim (K) for an in ≥ 1000A. The tightening torque of the screws is 14 N.m.

- Then put the 2 plastic covers on the back (Mark M).

- Pull the tab out at the back so that the product is triggered in case of unintentional extraction with a closed circuit breaker. The internal safety mechanism opens the unit at the first disconnection operation. This device prevents the circuit breaker from being disconnected. The handle must be in the triggered position (intermediate).

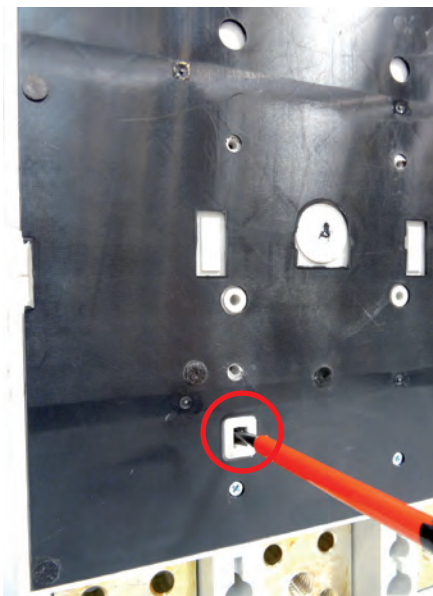

- Fix the DPX³ on the debro-lift mechanism with the screws of the product (tightening torque of 3 N.m.).
- After having set up the contacts and/or trigger inside the DPX³ and in case of wires passing on the side of the product, put the protective plastic cover of the wires (Mark Z) :

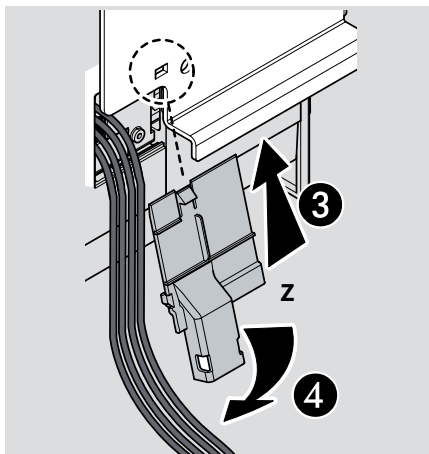

- Place the metal tab (R-mark) in the intended location and fasten it with the screw to the 2 N.m. torque: this part is used to prevent the locking in the connected position.
- Remove the handle cover, remove the 4 screws from the front cover for the 3P. For the 4P, leave the 2 fastening screws.
- Fasten the frame for the debro-lift using the screws provided. The screw marked W is placed on the top right.
- Set up the new handle cover and tighten the screw to 0.5 N.m.
- Fix the terminal shields at the rear of the screws marked T to the torque of 1 N.m.
- It is possible to seal them (mark U).

- With the help of the handle, turn the mechanism of the base to the maximum counter clockwise.
- Insert the product equipped with its debro-lift mechanism.
- Perform a full cycle of drawing-in/ drawing-out and check that the visual positions are correct: Green → disconnected, yellow → test, red → connected.

3 ISOLATED HANDLE FOR DRAW-OUT FO DEBRO-LIFT DPX³ (CAT.NO 0 265 75)

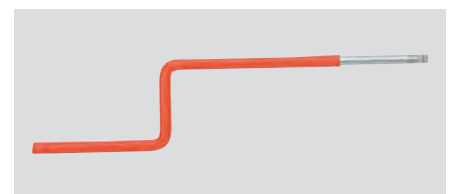

4 KEY-LOCK FOR DEBRO-LIFT CAT.NO 0 265 76 (FLAT KEY) / 0 263 48 (STAR KEY)

The mounting is identical to the DPX³ 630 (see page 42). Be careful however to take the right cam at the back, it is different :



DPX³ 1600

DPX³ 630

5 ROTARY HANDLE DIRECT ON DPX³ (CAT.NO 0 262 61)

Composition of the Cat.no :

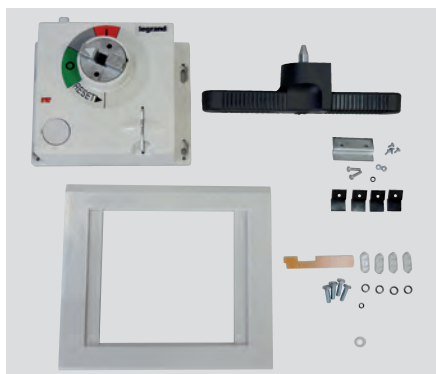

■ Mounting

- Position the DPX³ in the open position (OFF) :



- Remove the 4 screws (3P) or 6 screws (4P) from the front panel.

- Remove the 2 retaining screws from the identification frame (Torx T10) and remove it :

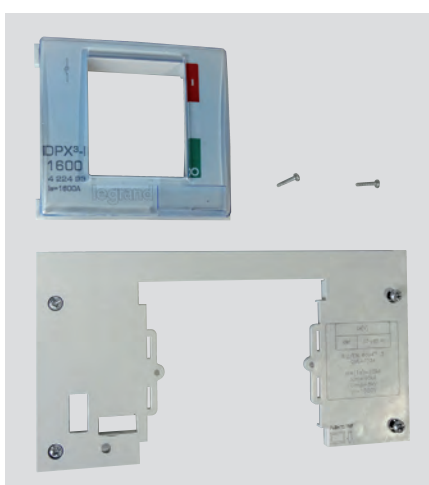
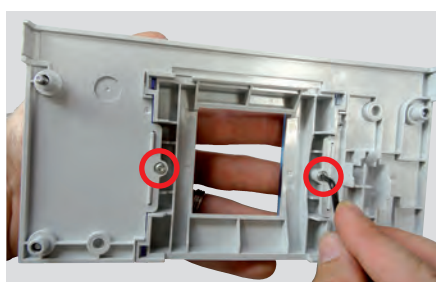

- Drill 4 holes using a 5 mm drill bit as shown in the instructions :

Back view

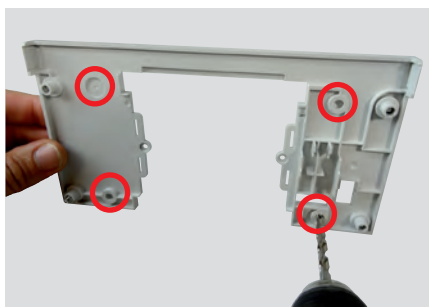

Front view

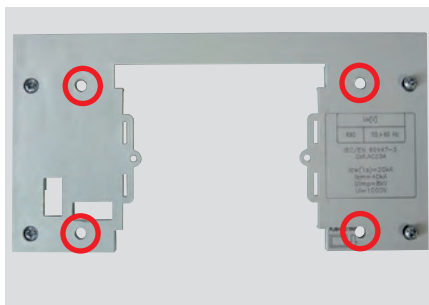

- Position the yellow tab and the plastic spacer in the indicated places :

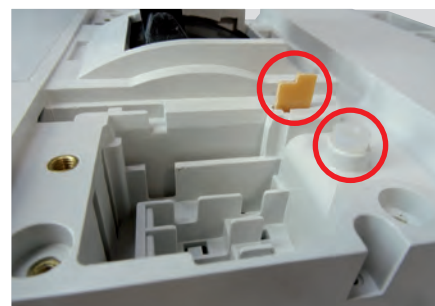

- Replace the front panel and fasten it.

- Remove the handle retaining screw and then the handle.

- Take the mechanism of the rotary handle and position it so that the metal tab is out :

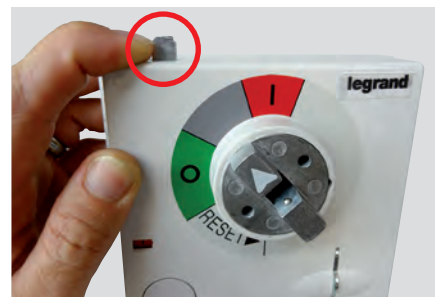

- Press the Red "test" button on the DPX³ (product position: triggered).
- Set up the rotary handle mechanism and secure it with the supplied screws by placing the handle correctly :

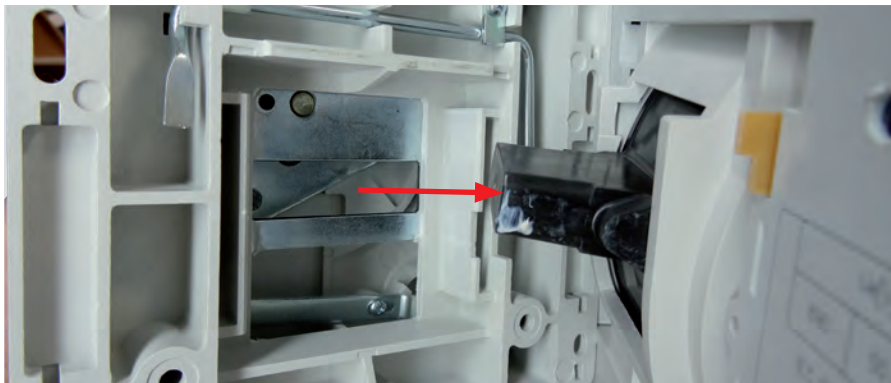

- Place the plastic frame on the faceplate as well as the retaining tabs :

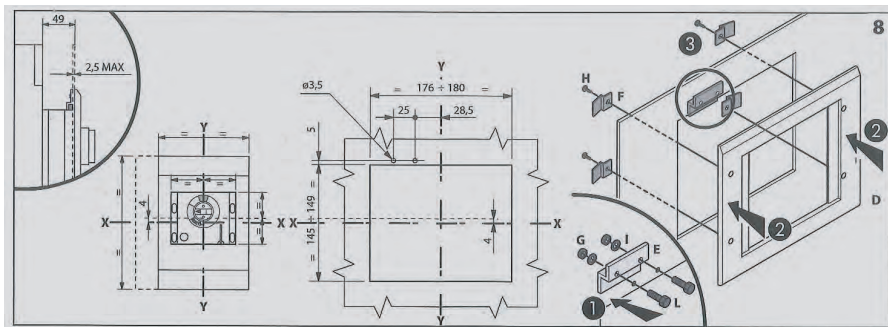

- Set up the screw covers.
- Check the correct operation of the whole as well as the tab :



Position "I": impossible to open the faceplate
 Test position (triggered): impossible to open the faceplate
 Position "0": possible to open the faceplate

6 DPX³ KEY-LOCK-DRAW-OUT POSITION (MOTORISED OR WITH ROTARY HANDLE CAT.NO 0 265 79/0 265 80)

This accessory allows you to lock the product (motorized or with rotary handle) in the disconnected position → perform a consignment operation.

The product comes with a unique key.

i It is possible to have the key number customizable with the company STI Montreuil (<http://www.servtrayvou.com/web/contact>) by giving the profile number: flat key N ° ABA90GEL6149 or star N ° HBA-90GPS6149.

The mounting is detailed in the instructions of the debro-lift mechanism (Cat.no 4 225 93/94). See also paragraph 5.2 of the "mechanical accessories" for DPX³ 630.

7 IP 55 VARI DEPTH HANDLE CAT.NOS 0 262 83 (STANDARD) OR 0 262 84 (EMERGENCY)

First perform the same operations as the rotary handle direct and then define the need for the IP and the presence of a lock or not :

- **IP55 without locking**, follow steps **A** of the instructions (see configuration below) :

- **IP55 with locking**, follow steps **C** of the instructions (see configuration below) :

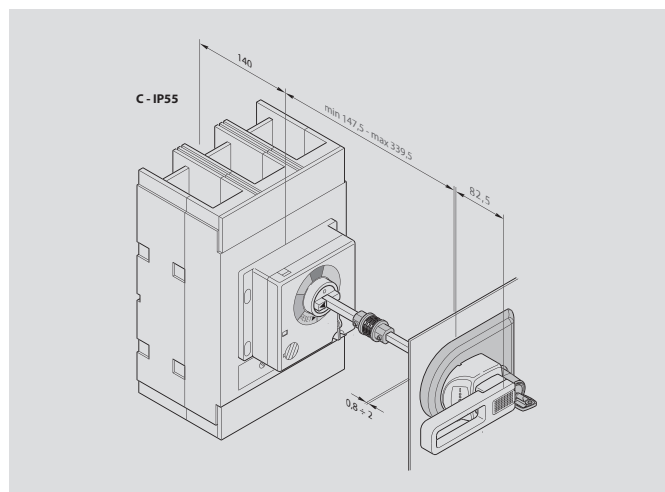
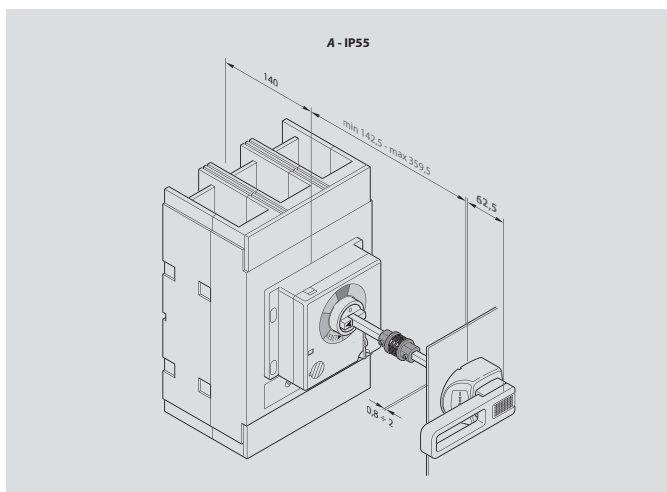

- **IP40 without locking**, follow steps **B** of the instructions (see configuration below) :

- **IP54 with locking**, follow steps **D** of the instructions (see configuration below) :

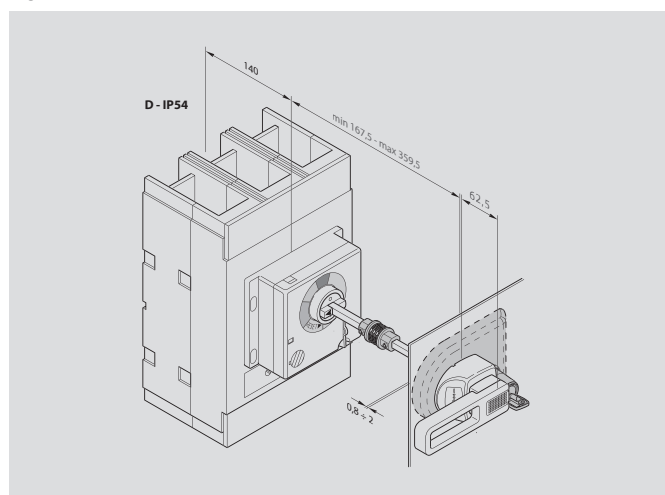
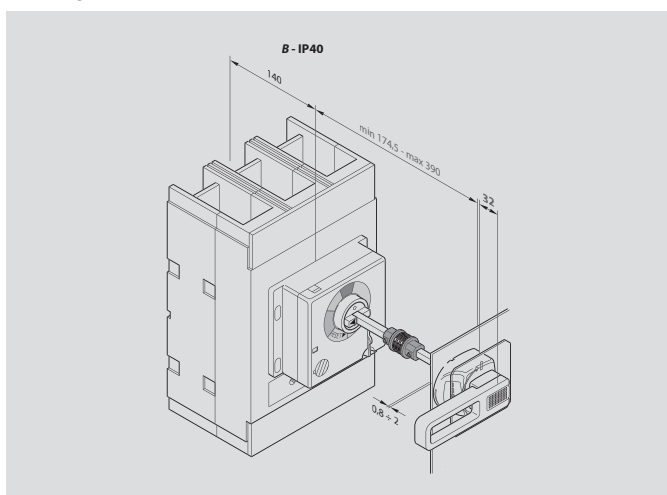

- **IP40 with locking**, follow steps E of the instructions (see configuration below) :

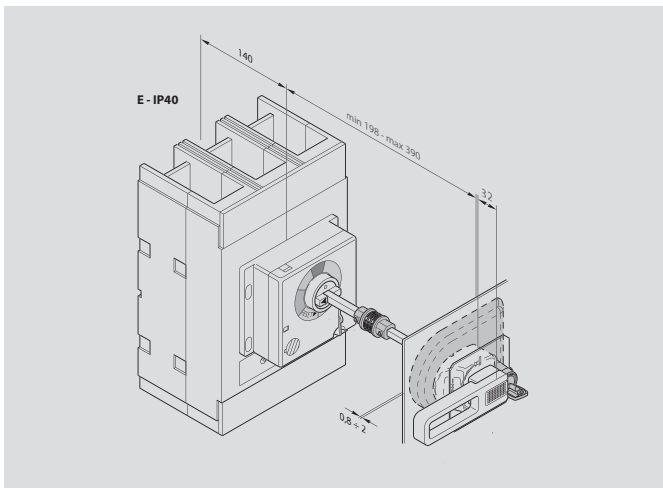

- It is then necessary to define the length of the axis according to the configuration: A, B, C, D or E :

Configuration A & B:

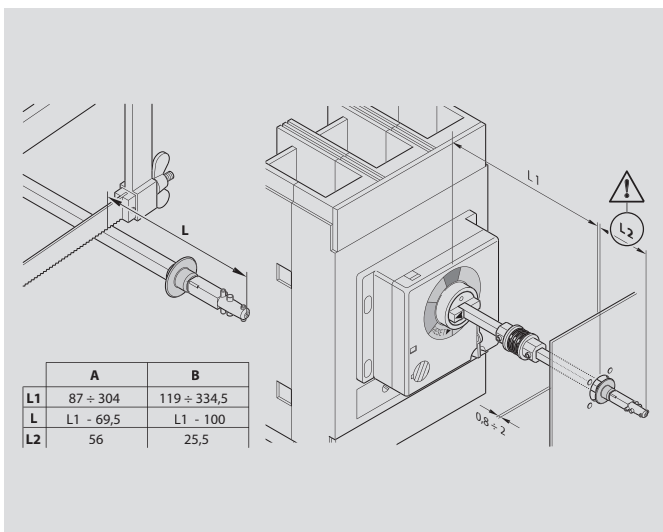

Configuration C, D & E:

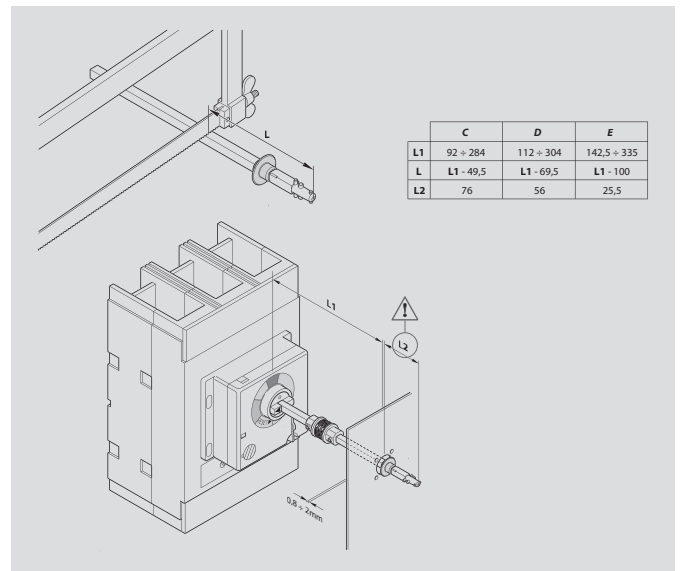

- Once the axis has been cut, carry out the mounting (depending on the IP) of the handle following the instructions.

Example of the installation in IP55 without locking :



! The opening of the door or the faceplate is only possible with the handle of the DPX³ in position "0" (OFF).

8 KEY LOCK FOR VARI-DEPTH ROTARY HANDLE - (STAR KEY CAT.NO 0 262 93/FLAT KEY CAT.NO 0 262 94 OR EUROLOCK KEY CAT.NO 0 262 92 OR 4 228 04/805

This accessory allows the DPX³ to be locked in the open position → perform a consignment operation.

Composition of the Cat.no 0 262 93 :



Make the mounting as shown in the instructions and check the correct operation of the whole: the key can be removed with the handle in position "0", it cannot be with the handle in position "I".



This lock can receive padlocks (3 maximum from 5mm to 8 mm).

Picture of the set mounted with the handle on "0" and the key removed :



Summary :

- 0 262 93 : each reference comes with 1 single star key
- 0 262 94 : each reference includes 1 single flat key
- 4 228 04 : each reference includes 1 flat key EL 43525 common to all Cat.no 4 228 04
- 4 228 05 : each reference includes 1 flat key EL 43363 common to all Cat.no 4 228 05

9 LOCKING FOR ROTARY HANDLE (CAT.NO 0 262 25)

Mounting identical to DPX³ 630 (see page 44).

10 CAGE TERMINAL (X1) CAT.NO 0 262 69/70

Composition of the Cat.no 0 262 69:



- Insert the 2 screws respecting the 2 different lengths and tighten the cage terminal on the product to the torque of 14 N.m. :

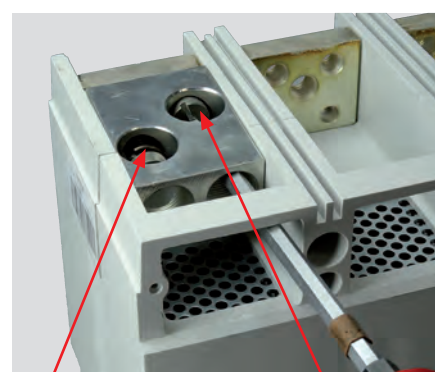

Location of the large screw

Location of the small screw

- Put the cables in place and tighten the screws to the torque of 36 N.m. (10 mm Allen).

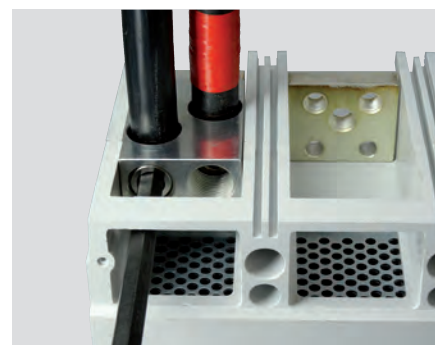

■ Cable characteristics :

- Stripping length → 25 mm
- Maximum cable Ø → 22 mm
- Maximum copper/aluminium section :
 - 2 x 240 mm² rigid
 - 2 x 185 mm² flexible
- Copper/aluminium minimum section :
 - 2 x 120 mm² rigid
 - 2 x 95 mm² flexible

■ Cat.no 0 262 70



- Insert the 2 screws into the cage terminal and tighten it on the product using an Allen key of 8 mm to the torque of 14 N.m. :

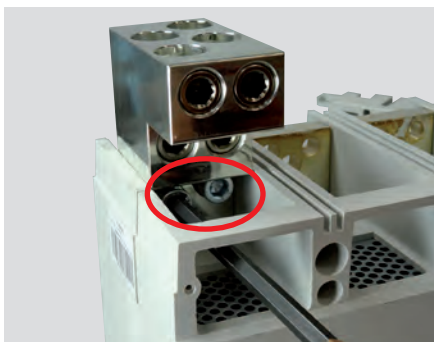

- Put the cables in place and tighten the screws to the torque of 36 N.m. (10 mm Allen-type).



■ Cable characteristics

- Stripping length
→ 58 mm for the 2 terminals of the bottom
→ 30 mm for the 2 front terminals
- Maximum cable Ø
→ 22 mm
- Maximum copper/aluminium section :
 - 4 x 240 mm² rigid
 - 4 x 185 mm² flexible
- Copper/aluminium minimum section :
 - 4 x 120 mm² rigid
 - 4 x 95 mm² flexible

11 EXTENDED FRONT TERMINALS (CAT.NOS 0 262 67/68)

■ Cat.no 0 262 67 (up to 1250 A) for flat bars or lugs.



The Cat.no includes only one piece, to be ordered by the required number.

- Flat bars → 50 mm maximum (width) x 10 mm (thickness) maximum Ø 14 mm hole drilling
- Terminals → 50 mm maximum (width) Ø 14 mm hole drilling
- Install the spacer (2 holes) and then the extension cord and fasten the whole with the screws provided (8 mm Allen type thumbprint, 14 N.m. tightening torque).

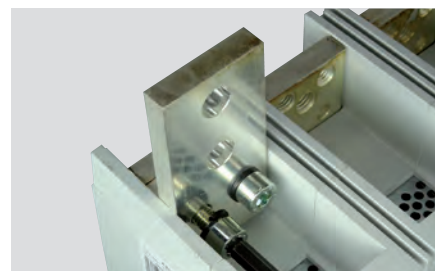

Forbidden to position 2 terminals side by side, they must be placed on either side of the extended front terminals.

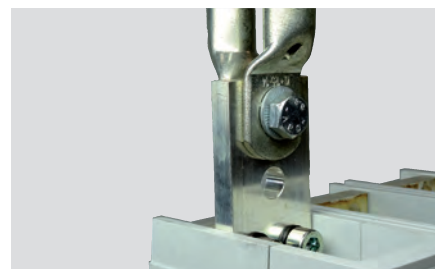

The mounting bolts of the bars or terminals on the extended front terminals are not provided.

■ Cat.no 0 262 68 (1600 A) : for flat bars

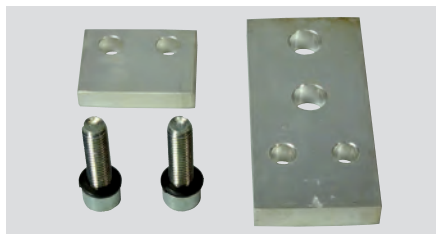

The flat bars must have a width of 50 mm maximum.



The thickness of the bars must be 10 mm.

The diameter of the drilling hole must be 14 mm.

- Start by putting a spacer, an extended front terminal, the other spacer and the second extended front terminal.
- Insert the 2 screws into the extended front terminal and the DPX³ terminal without tightening.
- Set up the flat bars (2 or 3) equipped with the bolts (not supplied).
- After blocking the bolts, finish tightening the terminal screws using an Allen key of 8 mm to the torque of 14 N.m.

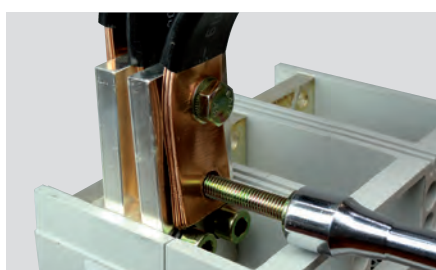
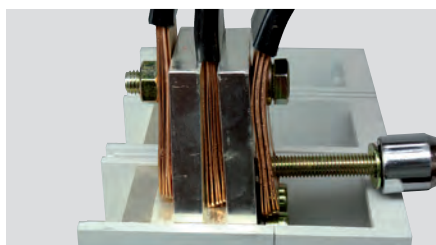

12 INCOMING AND OUTGOING SPREADERS CAT.NO 0 262 73 (3P) / 0 262 74 (4P)

Composition of the Cat.no 0 262 73 :



- Put in place the extended front terminals and tighten the fastening screws (2/ extended front terminals) using an Allen key of 8 mm to the torque of 14 N.m.



For the 3P (Cat.no 0 262 73), there are 2 small (identical) and 1 large.

For the 4P (Cat.no 0 262 74), there are 2 small (identical in the middle) and 2 large (located at the ends).

Dimensions L1 & L2 :

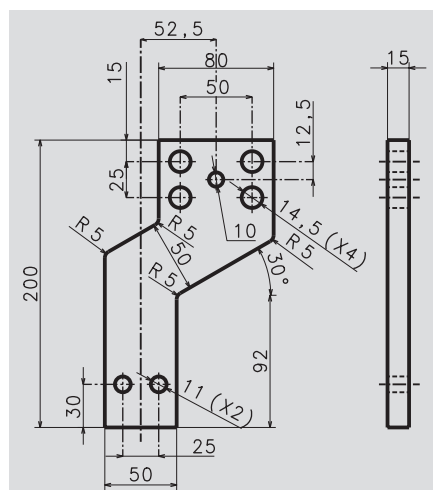

Dimensions L3 & Neutral if 4 poles :

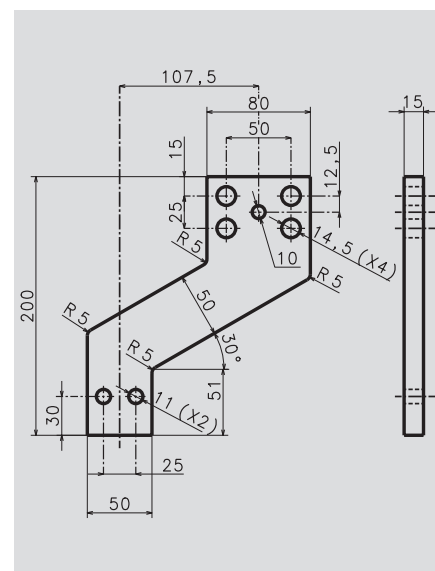

Example of mounting Cat.no 0 262 73 :

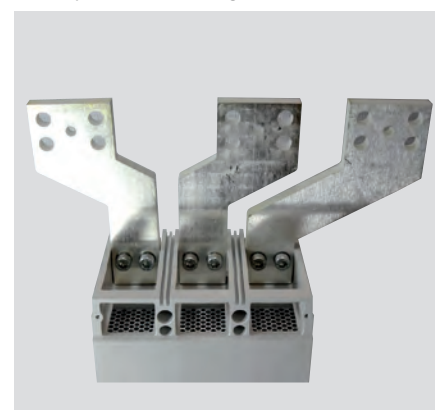

13 SET OF 3 INSULATED SHIELDS (CAT.NO 0 262 66)

Their role is to avoid the propagation of an electric arc in the event of a short circuit. We only need 2 insulated shields downstream (or upstream) for a DPX³ 3P.

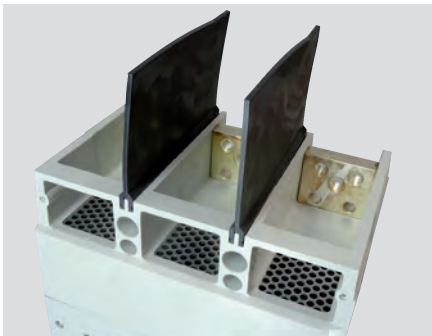
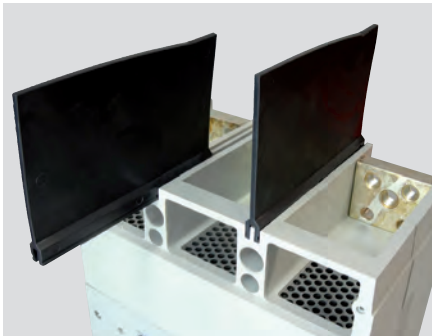

14 SET OF 2 SEALABLE TERMINAL SHIELDS CAT.NO 0 262 64 (3P) / 0 262 65 (4P)

Composition of the Cat.no 0 262 64 :



- Set up the guide-stoppers in the intended housing :

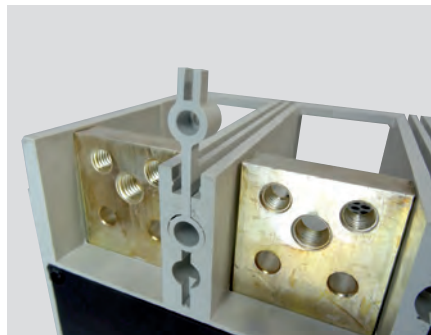
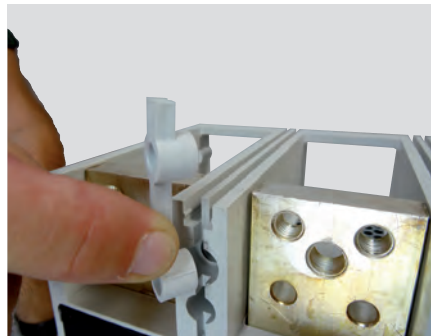

- Fix a bar (without tightening) to the connection range of the DPX³, position the sealable terminal shields and place the protection on it so as to make the marking for the cutting :



- Perform the same for the rear part of the bar.

- Remove the bar, insert the first part of the protection then the bar (with a definitive tightening) then the second part of the protection :



- Repeat these operations for all connection ranges.

- Perform the sealing(s) of the sealable terminal shields if necessary :



i In case of cable installation, make the cuts of the protections using a file according to the section.

15 SET OF TERMINAL COVERS - IP20 (FLAT) CAT.NO 4 225 90 (3P) / 4 225 91 (4P)

■ **Example of terminal cover 3P mouting :**

- Insert the terminal cover into the holes provided in the DPX³ to the clip :

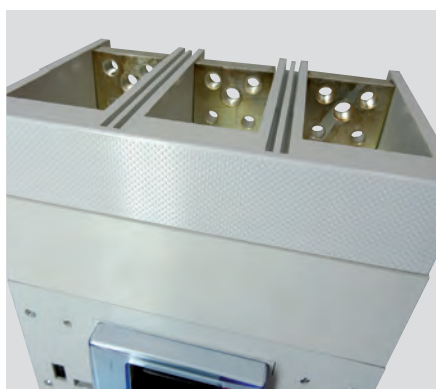

16 PADLOCK FOR LOCKING IN "OPEN" POSITION (CAT.NO 0 262 60)

Composition of the Cat.no :

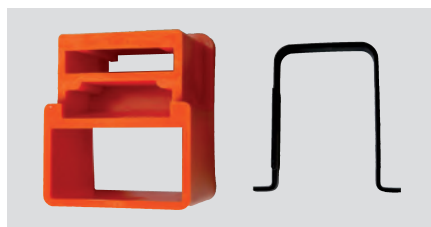

- Position the product in the open position (OFF).

- Insert the part in the form of Omega (Ω) in the lateral openings of the DPX³ at the position 1 :



- Place the orange plastic piece on the handle and the Omega-shaped part (Ω) :

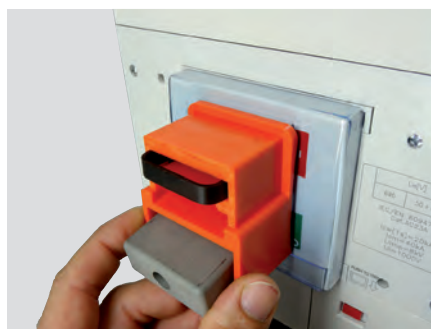

- Insert the padlock(s). It is possible to put 4 maximum padlocks with a diameter of 6 mm minimum to 8 mm maximum. Example with 1 padlock Cat.no 0 227 97 :



17 REAR TERMINALS (UPSTREAM AND DOWNSTREAM)

Composition: long connections for DPX³ 3 poles.



Mounting :

- Adapt the installation of the shims according to the intensity :
 - I < 800A → spacer 1.5 mm thick + spacer 4 mm
 - I ≥ 1000A → I ≥ 1000A → spacer 1.5 mm thick

Example with the mounting of the 2 spacers :

4 mm spacer 1.5 mm spacer in
behind the connec- front of the connec-
tion terminal tion terminal

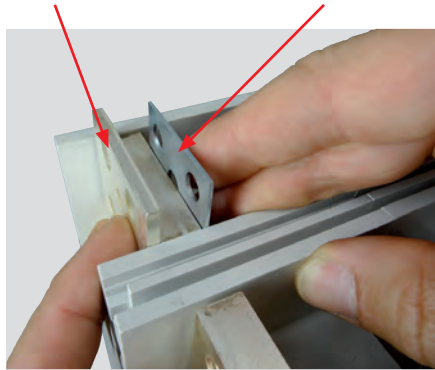

- Set up a rear terminal with 4 square nuts, the 4 Spring lock washers and the 4 CHC screws.
- Tighten the 4 screws to the torque of 15 N.m. (6 mm Allen).

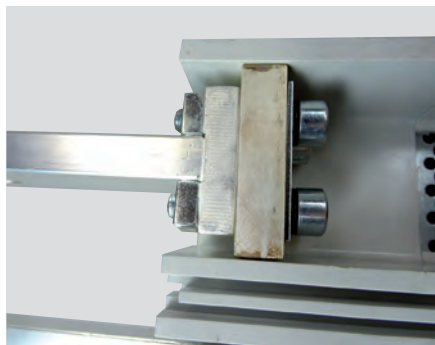

 It is possible to position the rear terminals (horizontal) or in vertical position (90°), the fixing holes of the terminals or bars are therefore on the top or on the side.

Example of the 2 mountings :

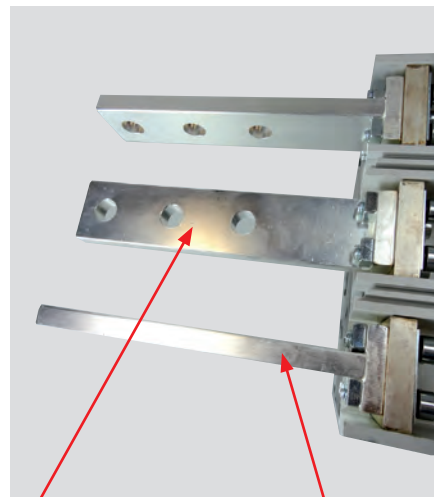

Horizontal Vertical



- Repeat these operations for all rear terminals (6 or 8).
- Set up the 2 grey plastic fixing frames and fix them to the plate using the hexagon head screws (M8), flat washers, spring washers and nuts.

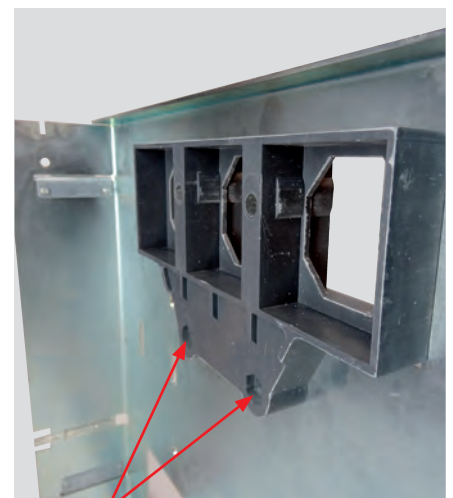

Location for inserting screws (front part)



Rear part

- Place the guide-stoppers in the places indicated on the DPX³ as well as the insulated shields on the plastic frames :

Guide-stoppers

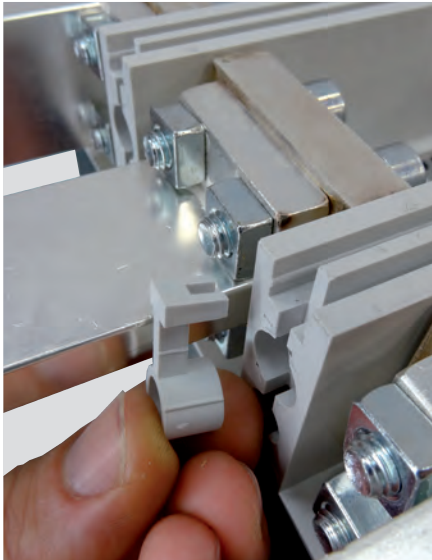

Insulated shields



- Fix the DPX³ in the inserts of the plastic frame using the screws supplied with the circuit breaker (or switch) :



- Set up the 2 sealable terminal shields as well as the seal(s) if necessary :



PCS SOFTWARE

Legrand power control station is intuitive and easy to use. It is a tool for consulting and testing the proper functioning of the electronic card that equips our electronic devices of the DMX³ range (except DMX³ 1600)-all electronic and thermal magnetic with integrated fault current protection DX³ add-on modules with integrated measurement-CX³ EMS. It is very useful for the maintenance service, to check the shape of the adjustment curve, to visualize the fault history and to check the different parameters directly on the device without touching the device. The software is available in 13 languages.

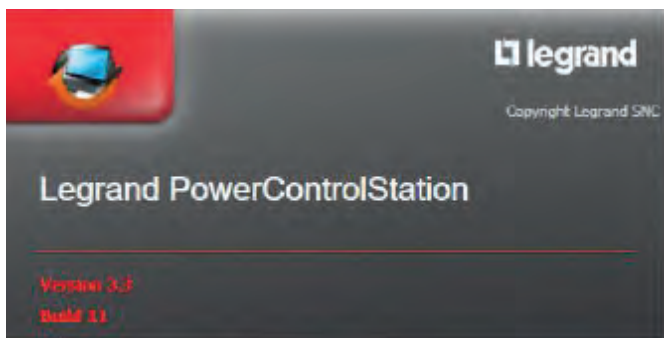

THE MINIMUM REQUIREMENTS OF THE COMPUTER TO RUN THE SOFTWARE :

- PC with Pentium III class processor
- Minimum RAM memory required 1GB, recommended 2GB
- Resolution 1024 x 768
- Colors 32 bit
- Pre-requisite mouse software
- Windows 7 or higher
- Microsoft.NET 4.0 or upgrade

■ Mini USB cable type B



The different access levels are available for each user category:

- Standard user → no password
- Business user → password 0000
- Legrand technical support → confidential
- Reserved area → confidential

COMPATIBILITY TABLE WITH VERSION 3.3 PCS :

Product	Version	Range	Minimum compatible version
DMX ³	MP4	2500-4000-6300	Screen software 2.5.5.X
	MP6	2500-4000-6300	Screen software 3.2.X

Product	Version	Range	Minimum compatible version
DPX ³	160	Thermal magnetic with earth fault protection	rev. 5 (*half 2016)
		Only earth fault protection	rev. 5 (*half 2016)
	250	Thermal magnetic with earth fault protection	rev. 5 (*half 2016)
		Only earth fault protection	rev. 5 (*half 2016)
		Electronic	rev. 4
		Electronic with earth fault protection	rev. 4
	630	Electronic	rev. 4
	1600	Electronic	rev. 2

The installation procedure and connection to the software, please refer to the instructions LE08865AB.

The different functions of the software :

- Firmware update: run the device firmware update feature. This operation is reserved exclusively for Legrand qualified personnel.

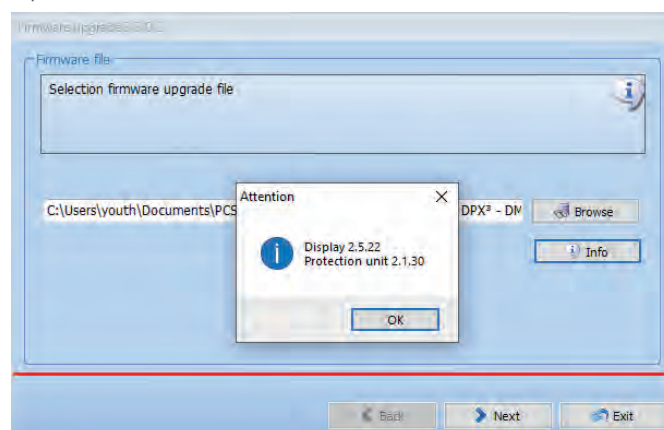

- Print on the file: create a complete file containing all the data read by the software and present on the device. ("..\Documents\legrand\legrand_powercontrolstation_03xx \ log").

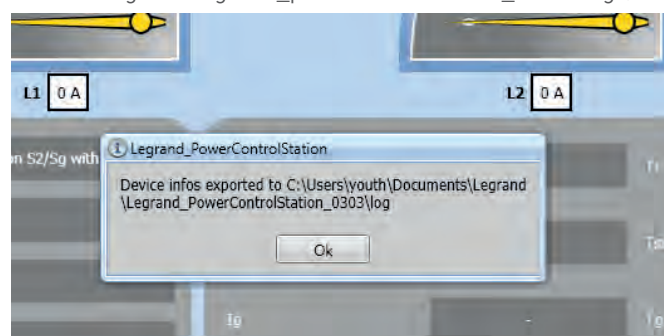

- Start monitoring: read the device information (versions – parameters – fault histories, etc.). The different pages of readings :

The yellow/white bar at the bottom of the page on the right is activated.

■ Home page

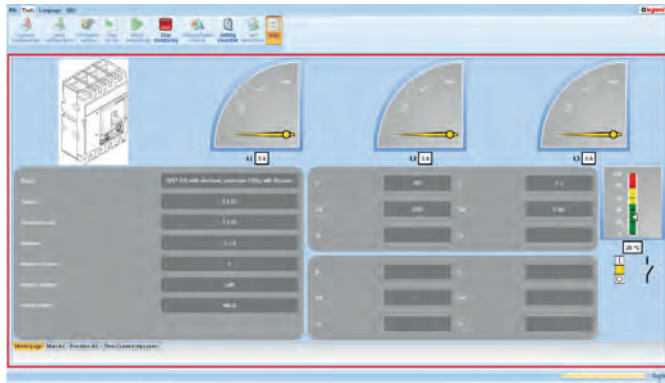

■ General list

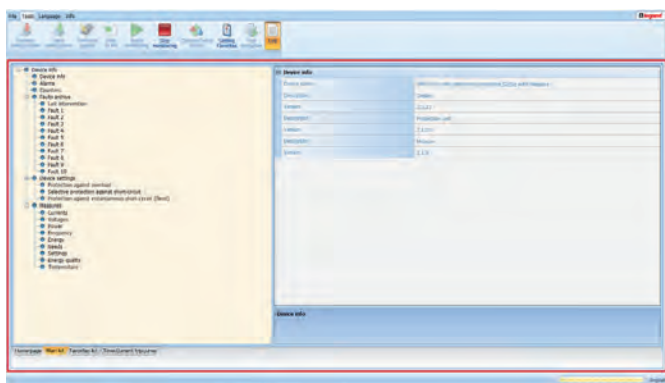

■ Favorites list

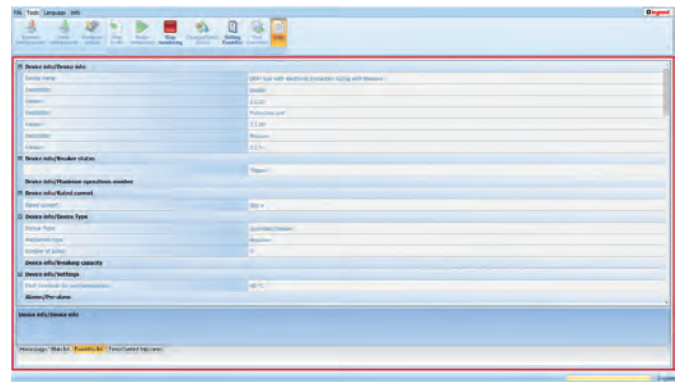

■ Tripping curves

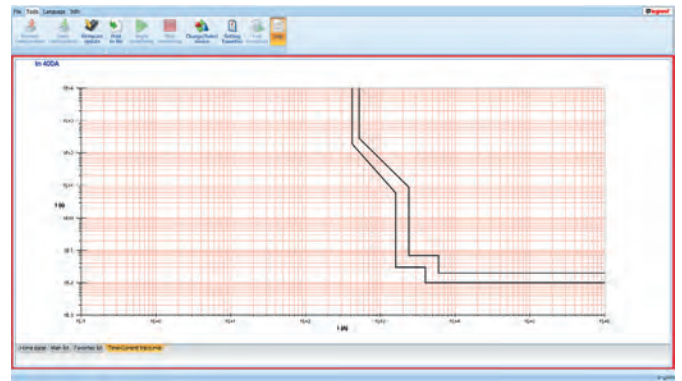

- Stop monitoring: stop playback of the device (the yellow/white bar at the bottom of the page on the right is no longer active).

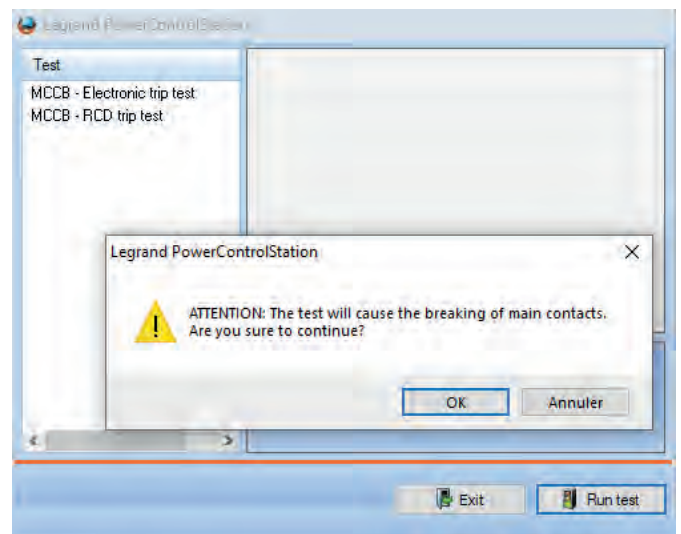

- Change/select device: in case of a prolonged shutdown, click on this tab to refresh the connection with the connected device.
- Favorite setting: in this tab, you can find all the information gathered on a single tab, version of the device, its settings, defect histories, etc...
- Test run: allow the device to be checked for proper operation. Attention, to ensure proper operation of this test, it is imperative to check that the device is properly powered (external power supply for electronic circuit breaker and mains supply for differential circuit breaker).

- Log: create and save the different steps of communication with the device (for all operations of the firmware update, think about clicking "Log").

SPECIFIC FUNCTIONS

Integrated measurement

With the new electronic DPX³ circuit breakers with integrated measurement, it is very easy to monitor the parameters of the different circuits of the installation without any external device, without current transformer or additional voltage socket.

The measured data can also be consulted remotely on a computer equipped with a supervision software, via the communication interface Cat.no 0 046 89.

The integrated measurement is available on the DPX³, making sure that the DPX³ electronic card is powered by the external power supply Cat.no 4 210 83 or by the communication interface MODBUS Cat.no 4 210 75.

The measured values are displayed directly on the LCD screen in front of the devices, or available on the MODBUS network.

The measurement part of the electronic card remains independent of the proper operation of the protection part of the DPX³.

Internal batteries, accessible from the front of the product, allow the consultation and adjustment of the different protection parameters without main voltage source.

The integrated measurement function is available in the DMX³, DPX³ and DX³ ranges.

The touch screen Cat.no 0 261 56 installed on the door of the cabinets is an innovative solution that allows to visualize information from 8 devices: DX³, DPX³, DMX³ or EMDX³ measuring units.

Legrand also offers a complete range of meters, measuring units and current transformers for installations equipped with devices without integrated measurement.



 The technical guide: energy management in an electric board is available for download on <http://www.export.legrand.com/>.

THE MEASUREMENT INTEGRATED IN DPX³ 630-1600 ALLOWS A READING OF THE FOLLOWING QUANTITIES, IN THE ORDER OF DISPLAY :

- I1: current phase 1-A (1).
- I2: current phase 2-A (1).
- I3: current phase 3-A (1).
- In: neutral current (for DPX³ 4P)-A (1).
- IG: Earth current (for SG version)-A (1).
- U12: compound voltage between phases 1 and 2 (for DPX³ 3P/4P)-V.
- U23: compound voltage between phases 2 and 3 (for DPX³ 3P/4P)-V.
- U31: compound voltage between phases 3 and 1 (for DPX³ 3P/4P)-V.
- U1N: single voltage between neutral and phase 1 (for DPX³ 4P)-V.
- U2N: single voltage between neutral and phase 2 (for DPX³ 4P)-V.
- U3N: single voltage between neutral and phase 3 (for DPX³ 4P)-V.
- Freq: frequency-Hz.
- PTOT: active power-kW.
- Qtot: reactive power-kvar.
- PF: power factor.
- Ep ↓ : active energy meter consumed or returned, with a direction of passage from the top terminals to the bottom-kWh terminals.
- Ep ↑ : active energy meter consumed or returned, with a direction of passage from the bottom terminals to the top-kWh terminals.
- Eq ↓ : reactive energy meter consumed or returned, with a direction of passage from the top terminals to the bottom-kvarh terminals.
- Eq ↑ : reactive energy meter consumed or returned, with a direction of passage from the bottom terminals to the top-kvarh terminals.
- THDU12 : Harmonic rate of the compound voltage between phases 1 and 2 (for DPX³ 3P/4P)-%.
- THDU23 : Harmonic rate of the compound voltage between phases 2 and 3 (for DPX³ 3P/4P)-%.
- THDU31 : Harmonic rate of the compound voltage between phases 1 and 3 (for DPX³ 3P/4P)-%.
- THDU1N : Harmonic rate of the single voltage between neutral and phase 1 (for DPX³ 4P)-%.
- THDU2N : Harmonic rate of the single voltage between neutral and phase 2 (for DPX³ 4P)-%.
- THDU3N : Harmonic rate of the single voltage between neutral and phase 3 (for DPX³ 4P)-%.
- THDI1 : phase 1-% current harmonic rate.
- THDI2 : phase 2-% current harmonic rate.
- THDI3 : phase 3-% current harmonic rate.

⁽¹⁾Also accessible on electronic DPX³ without measuring unit..



To navigate from one value to another, you have to press "↗". Going back is impossible, you have to take a whole tour.

SPECIFIC FUNCTIONS

SELECTIVITY

Several techniques are used to achieve selectivity :

- Current sensing selectivity, used for final circuits with low short-circuit levels,
- Time selectivity, ensured by a delay in triggering the upstream circuit breaker,
- Dynamic selectivity, optimally using the characteristics of Legrand devices in the energy zone,
- Logical selectivity, taking advantage of the possibilities of communication between devices in the energy zone.

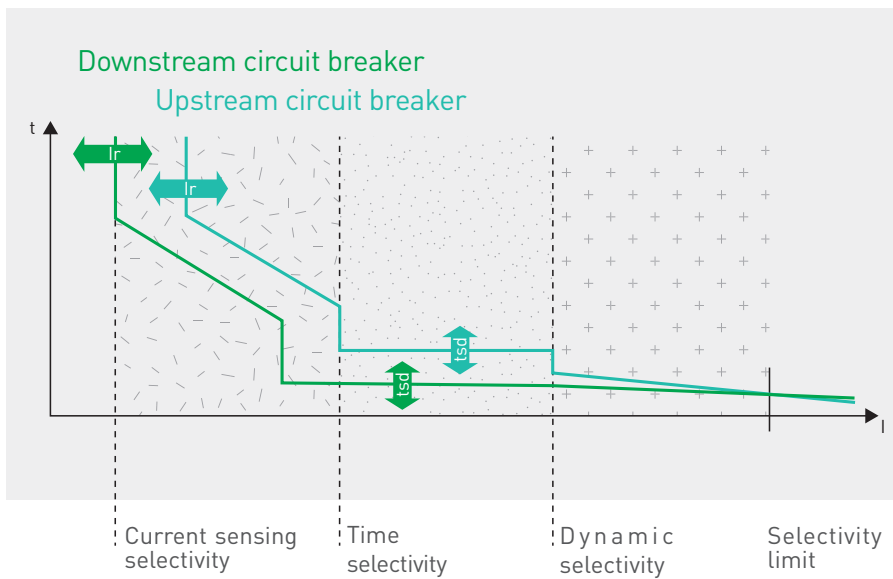

■ The current sensing selectivity

This technique is based on the intensity of the upstream and downstream circuit breaker tripping curves. It is checked by comparing these curves making sure that they do not overlap. It applies to the overload area and the short circuit area and the further apart the ratings of the devices, the better the selectivity:

- On overloads :

To have selectivity in the overload area, the ratio of the adjustment currents (I_r) must be at least equal to 2.

- On short-circuits :

For selectivity in the short-circuit area, the ratio of the magnetic adjustment currents (I_{sd}) must be at least equal to 1.5.

The ampere-metric selectivity is well suited for final circuits where short circuit levels are relatively low.

■ Time selectivity

This technique is based on the time lag of series circuit breaker tripping curves. It is checked by comparison of curves and applies for selectivity in the area of short circuits. It is used in addition to the current sensing selectivity in order to obtain a selectivity beyond the magnetic adjustment current of the upstream circuit breaker.

It is then necessary that :

- it must be possible to set a time delay on
- the upstream circuit breaker is capable of withstanding the short circuit current and its effects for the duration of the delay
- the trunking through which travelled by this current passes can withstand the thermal stresses (I^2t).

The non-triggering time of the upstream unit shall be longer than the breaking time (including a possible delay) of the downstream device. DPX³ circuit breakers have several adjustment positions for their time-out in order to achieve multi-stage selectivity.

■ Dynamic selectivity

The electronic triggers of the DPX³ circuit breakers have an additional 2-level setting to reinforce their selectivity for achievements for which the requested selectivity level is maximum.

- "low" for a normal selectivity level.
- "high" for a high selectivity level.

This technique allows to take advantage of the performance of the Legrand devices in compliance with the installation. When there is no particular selectivity requirement or if the device protects a terminal circuit, the activation of this function is not necessary.

These two settings appear in the drop-down menu of the electronic DPX³.

■ Logical selectivity

Logical selectivity is a "smart" selectivity that is achieved by communicating between the interconnected DPX³/DMX³ electronic circuit breakers through an external wired connection.

The logical selectivity intervenes on the short-delay and instantaneous operating areas of the tripping curve.

It concerns short-circuits of medium and high intensity (energy part).

It does not act on the long delay part of the curve (current sensing selectivity) dealing with overloads.

Electronic release

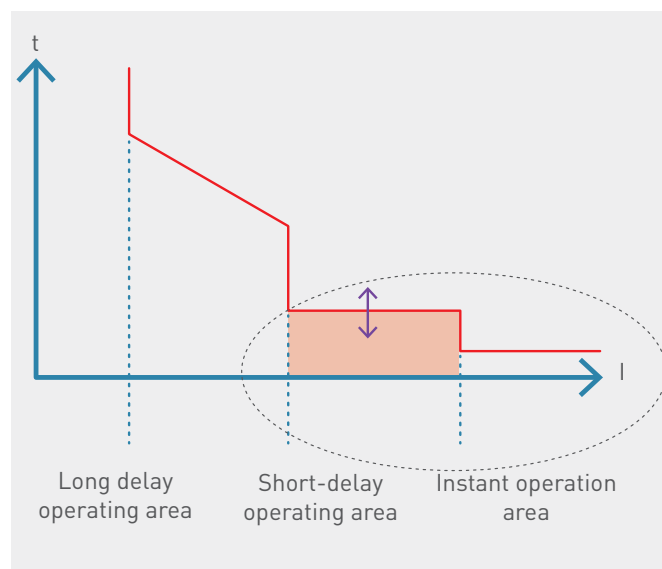

IDENTICAL ACCESSORIES

Auxiliary contact or fault signalling contact Cat.no 4 210 11

All DPX³ circuit breakers and switches can be equipped with electrical auxiliaries to ensure control functions.

PRINCIPLE

The auxiliary/fault contact Cat.no 4 210 11 is identical for the entire DPX³ range.

Depending on the location in the DPX³ case, the changeover contact acts as an auxiliary contact, or as a fault signal contact.

The auxiliary contact (OC) allows the signalling of the position of the main contacts of the circuit breaker or of the switch (open or closed) when it is operated by its controller.

It is neither anticipated nor delayed.

The fault contact (CTR) allows to remotely postpone the opening of the circuit breaker following an intervention of its trigger part (thermal magnetic, electronic or differential) or after pressing the test button or following the action of the shutter releases or a lack.

These contacts are of the inverter type (NO-NC) with dry contact (potential free).

DIAGRAM

Represented DPX³ in position "0" open:

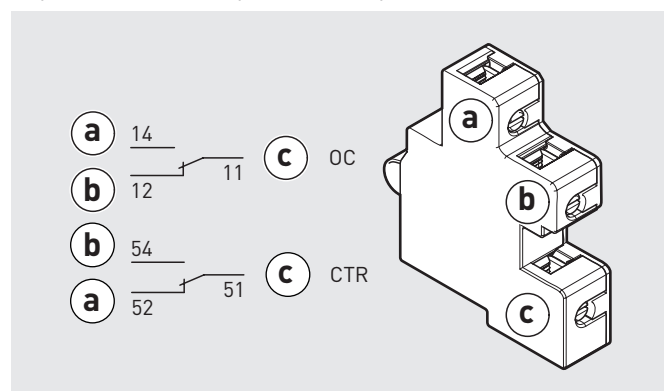

ELECTRICAL CHARACTERISTICS

VOLTAGE	CURRENT (A)	
	RESISTIVE LOAD	INDUCTIVE LOAD
24 Vdc	10	5
48 Vdc	1,3	0,7
110 Vdc	0,4	0,3
230 Vdc	0,3	0,2
110 Vac	10	4
230 Vac	6	2



Shunt releases

PRINCIPLE

The shunt releases allow the instantaneous opening (≤ 50 ms) of the device by the supply of their coils: negative safety (control by external contact NO).

The built-in trigger contact cuts off power of the shunt release during an opening commande:

DPX³ 630/1600 :



DIAGRAM

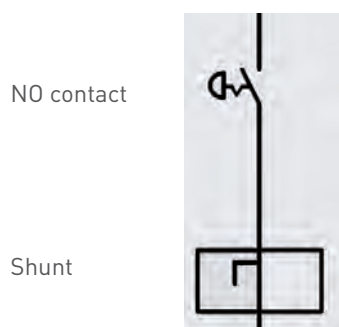

ELECTRICAL CHARACTERISTICS

	DPX ³ 630 - DPX ³ 1600
Operating range	70 to 110 % Un
Response time	≤ 50 ms
Inrush power	300 VA/W
Request time	> 50 ms
Isolation voltage	1,8 kV

CATALOGUE NUMBERS	DESIGNATION
4 222 39	24 V~ et =
4 222 40	48 V~ et =
4 222 41	110 V~ et =
4 222 42	230 V~ et =
4 222 43	400 V~ et =

Undervoltage releases

PRINCIPLE

The minimum voltage triggers allow the instantaneous opening (≤ 50 ms) of the device by switching off the power supply ($< 85\%$ UN) of their coils: positive safety (eg: emergency stop by external contact NF).



DIAGRAM

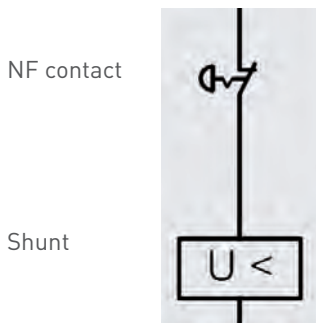

ELECTRICAL CHARACTERISTICS

	DPX ³ 630 - DPX ³ 1600
Operating range	85 to 110 % Un
Response time	< 50 ms
Holding power	1,6 W/5 VA
Isolation voltage	1,8 kV

CATALOGUE NUMBERS	DESIGNATION
4 222 44	24 V =
4 222 45	24 V ~
4 222 46	48 V =
4 222 47	110 V ~
4 222 48	230 V ~
4 222 49	400 V ~

Time-lag undervoltage release (800 ms) Cat.no 4 226 23

PRINCIPLE

Associated with a time-lag module Cat.no 0 261 90 (230V ~) or Cat.no 0 261 91 (400 V ~) (400V ~), it prevents unwanted tripping in case of network micro-breaks (see details on page 26).

CATALOGUE NUMBERS

Undervoltage release :
4 226 23

Time-lag module :
0 261 90



Residual current relay Cat.no 0 260 88

PRINCIPLE

Residual current relays make it possible to transform DPX³ circuit breakers and switches into differential, which are not originally foreseen, but must be equipped with a trigger.

DIAGRAMS

With the use of a coil with a lack of tension, it is necessary to reset the DPX³.

■ Positive safety position slider in Nd

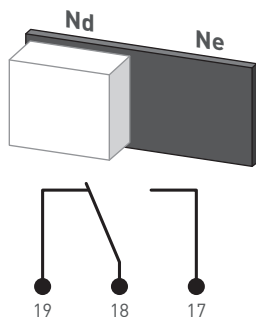

Position of contacts in powered device condition.

Warning: in case of fault of the connection coil-relay, the contact closes between terminals 17 and 18 irrespective of the position programmed on the selector.

In addition, in case of no voltage, the contact closes between 17 and 18 (opening of the associated circuit breaker).

With a shunt release :

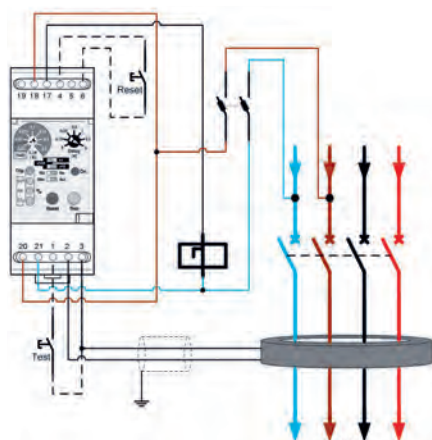

With an undervoltage coil :

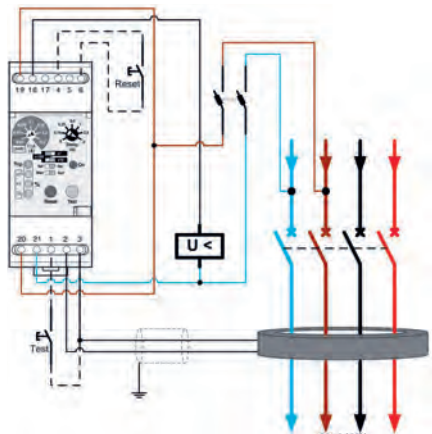

■ Standard safety position slider in Ne

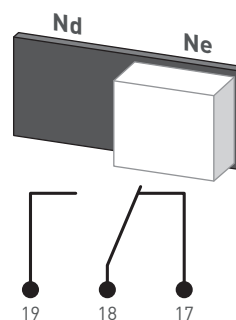

Position of contacts in powered device condition.

Warning: in case of fault of the connection coil-relay, the contact closes between terminals 18 and 19 irrespective of the position programmed on the selector.

i All active conductors must pass through the coil for proper operation of the relay, this excludes PE and PEN diagrams.

FRONT FACE

- 1- setting the $I\Delta n$.
- 2- test button.
- 3- reset button.
- 4- power indicator light (green).
- 5- indicator of the triggering of the residual current relay (red)/interruption relay-torus connection (flashing red).
- 6- timer setting.
- 7- selection of the multiple of the $I\Delta n$ calibre.
- 8- reset mode selection.
- 9- selecting the status of the output relay.
- 10- fault current indication in% $I\Delta n$.

SETTINGS

■ Sensitivity setting $I\Delta n$

The sensitivity of the residual current relay is obtained by a first combination of switch **7** used to determine the multiple of the rotary slider **1** refining the setting of the $I\Delta n$.

Depending on the torus used, the mini sensitivity may vary. If the set value of the $I\Delta n$ is less than its mini value, it is the latter that will be taken into account.

Time-lag

Time-lag allows the trigger of the associated DPX³ to be delayed if the defect is maintained during this period.

With a setting of $I\Delta n$ at 0.03 A, regardless of the time delay recorded, the trigger will be instantaneous.

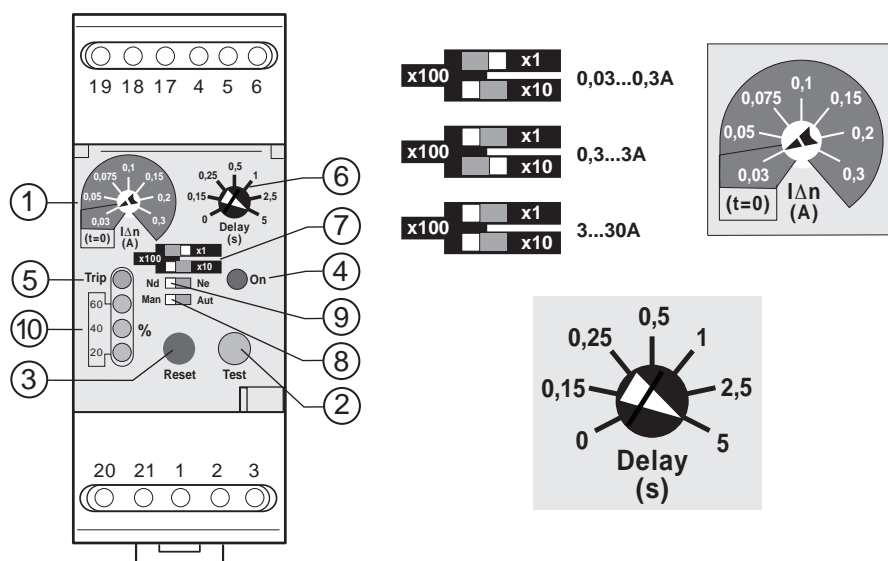

The residual current relay must be adjusted according to the need for differential selectivity in time and sensitivity.

IDENTICAL ACCESSORIES

COIL CHARACTERISTICS

Cat.no	0 260 92	0 260 93	0 260 94	0 260 95	0 260 96	0 260 97	0 260 98
Diame- ter (mm)	35	80	110	140	210	150	310
$I_{\Delta n}$ - mini (mA)	30	30	100	300	300	500	1000
I_n (A)	70	170	250	250	400	250	630
$I_{max} =$ (6x I_n)	420	1020	1500	1500	2400	1500	3780

■ Choice and recommendation :

This depends on the minimum residual current to be detected and the inner diameter of the coil to pass all active conductors. For a high transient current application, the standard requires on the manufacturer a maximum test threshold at 6 x I_n (immunization with false homopolar currents according to EN/IEC 60947-2 Annex M).

Example 1 : an installation consisting of ventilation systems with a nominal current of 150A.

According to EN/IEC 60947-2 Annex M, the coil to be selected is Cat.no 0 260 93: $I_n = 170$ A

6 x $I_n = 1020$ A

For a low transient current application less than 6 x I_n , this formula can be applied 6 x I_n (see table above).

I_n (nominal current of the unit).

Example 2 : for the coil Cat.no 0 260 93 with a device $I_n 150 = 6,8$

1020

150

The maximum permissible overload is 6,8 x I_n

$I_{\Delta n}$ mini : minimum threshold to be set on the differential relay depending on the size of the coil to avoid inadvertent triggering.

I_n : nominal current of the unit.

I_{max} : see choice and recommendation.

To ensure proper operation of the residual current relay, please follow the recommendations below :

- Reduce the distance between the coil and the residual current relay to a minimum.
- Use shielded or twisted cables.
- Do not put the connection cables of the coil and the residual current relay in parallel to the power conductors or close to electromagnetic fields (e.g. high voltage transformer).
- To achieve optimum accuracy, conductors must be centered in the coil.
- Different implementation options :

Case 1-flexible or conductive bars must be ensured that the 4 active conductors are inside the coil and centered :

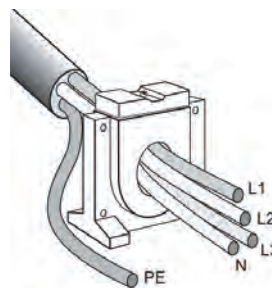

Case 2-by 5G cable for example, in case the PE passes through the coil, then this conductor must be put back in the opposite direction to regularize the field as the image below.

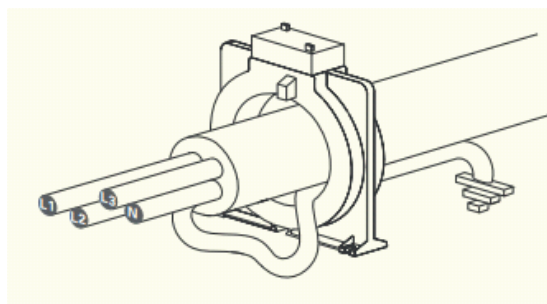





ACCESSORIES & SPARE PARTS

The DPX³ and the accessories of the range have dedicated spare parts.

PRODUCT	CAT.NO	DESIGNATION	CONTENT
DPX ³ 630	0 262 30	Insulated shields	 x 3
	0 263 50	Incoming or outgoing swivel terminals	 Upstream and downstream 3P
	0 263 51	Incoming or outgoing swivel terminals	 Upstream and downstream 4P
	9 802 56	Kit for DPX ³ 630	 3 insulated shields, 8 M8 screws, 8 washers, 4 fixing screws, 4 insulators, 4 nuts, 4 flat washers & 4 Grower lock washers
	9 802 64	Connection terminal	 1 plastic insulator & 1 nut
	9 802 68	Spare draw-out	 1 plastic guide & 1 screw
	9 802 69	Motor spare parts	 1 connector 8 wires, 1 plastic protection, 4 metric screws, 2 fixing screws for plastic protection, 1 motor fault lever + 1 axis, & 1 plastic tab
	9 802 97	Interlock fork	 x 1
	9 812 40	Kit spare handle	 7 black handles for circuit breaker, 3 grey handles for switch & 10 fixing screws
	9 812 41	Draw-out kit handle	 3 black handles + 3 fixing screws
	9 812 42	Draw-out front cover	 1 handle + 1 front cover
	9 803 86	Plugging internal wiring clip	 x 12

PRODUCT	CAT.NO	DESIGNATION	CONTENT
DPX ³ 1600	9 802 71	Spare draw-out 3P	 2 covers + 4 screws
	9 802 72	Spare draw-out 4P	 2 covers + 6 screws
	9 802 57	Kit for DPX ³ 1600	 3 insulated shields, 2 screw covers 4P, 2 screw covers 3P, 8 M8 screws x 60mm + 8 flat washers + 8 Grower lock washers, 24 M10 screws + 24 Grower lock washers
	9 802 70	Motor spare parts	 1 connector 8 wires, 1 connector 7 wires, 1 fault motor lever, 1 screw kit, 2 toothed washers 1 axis & 1 plastic cap
	9 802 98	Interlock fork kit	 2 plastic forks, 2 mouting plastic parts, 2 finger lever, 4 metric screws & 4 insert-nuts
	9 812 50	Kit spare handle	 7 black handles for circuit breaker, 3 grey handles for switch & 10 fixing screws
	9 812 51	Draw-out kit handle	 3 black handles + 3 fixing screws
	9 812 52	Draw-out front cover	 1 handle + 1 front cover, 1 handle guide + 1 screw, fixing screw kit
	9 802 73	Spare draw-out	 1 plastic guide & 1 screw
	9 803 85	Auxiliary transparent cover	 1 transparent plastic cover + 1 screw (x5)

ACCESSOIRES & SPARE PARTS

PRODUCT	CAT.NO	DESIGNATION	CONTENT	
DPX ³ 630/1600	0 290 52	Contact terminal		x 1
	4 210 82	Batteries kit		1 drawer for DPX ³ 160/250 1 drawer for DPX ³ 630/1600 2 CR1616 batteries DPX ³ 630/1600
	4 210 89	Mini-usb cover		x 20
	4 210 92	DPX ³ supply cables		x 20
	4 210 95	Sealing kit		x 4
	4 222 37	Retrofit kit DPX 630 - DPX ³ 630		1 lever, 4 countersunk screws, 4 flat head screws, 1 axis & 4 insert-nuts

Notes

To know more,

check export.legrand.com



All technical data of the products inside this workshop specifications book are available on : www.legrand.com/ecatalogue/

>Click on >LIBRARY OF DOCUMENTS

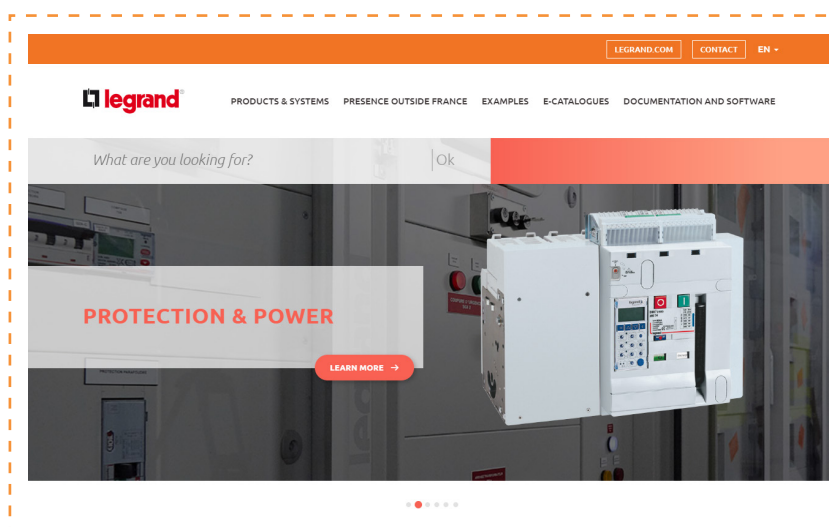

>Documentation

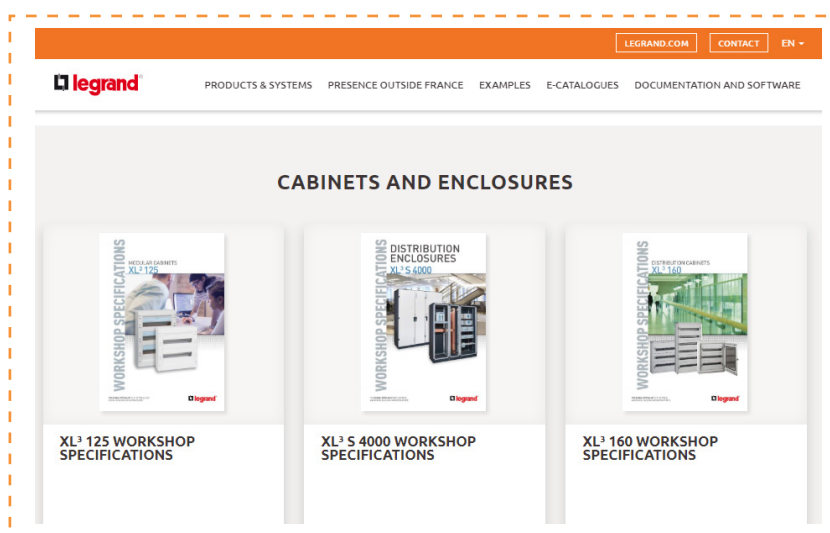



FOLLOW US
ON

@ www.legrand.com

 www.youtube.com/legrand

 twitter.com/legrand_news



Head office

and International Department
87045 Limoges Cedex - France

Tel: + 33 (0) 5 55 06 87 87

Fax: + 33 (0) 5 55 06 74 55